

# Feedthrough and Vacuum Window 馈通与真空观察窗



V 20260403

**ANDESUN**  
**安德信科技**

# CONTENTS 目录

1

## 企业简介

Company Introduction ..... 1

2

## 产品简介

Product Introduction ..... 3

3

## 同轴 2.92 型系列

Coaxial 2.92 Series ..... 4

4

## 同轴 SMA 型系列

Coaxial SMA Series ..... 5

5

## 同轴 N 型系列

Coaxial N Series ..... 13

6

## 同轴 BNC 型系列

Coaxial BNC Series ..... 19

7

## 同轴 L29 型系列

Coaxial L29 Series ..... 21

8

## 同轴 BPM 纽扣系列

Coaxial Bpm Buttons Series ..... 23

9

## 三同轴 TRB 型系列

Triple Coaxial TRB Series ..... 27

# CONTENTS 目录

10

## 大功率微波窗系列

High Power Microwave Window Series ..... 28

11

## 多针系列

Single Pin Series ..... 29

12

## 多针系列 — 焊线式

Multi-pin Series — Solderable ..... 31

13

## 多针系列 — GJB 598

Multi-pin Series — GJB 598 ..... 33

14

## 多针系列 — IEC 61076

Multi-pin Series — IEC 61076 ..... 40

15

## 多针系列 — MIL-DTL 5015

Multi-pin Series — MIL-DTL 5015 ..... 41

16

## 多针系列 — IEC 60807

Multi-pin Series — IEC 60807 ..... 42

17

## 耐高压系列

High Voltage Series ..... 44

18

## 大电流系列

High Current Series ..... 49

# CONTENTS 目录

19

## 真空隔离器系列

Vacuum Isolator Series ..... 53

20

## 真空观察窗系列

Vacuum Window Series ..... 55

21

## 定制化产品

Customized Products ..... 58

22

## 注意事项

Attentions ..... 60

23

## 生产流程

Production Process ..... 61

24

## 客户分布

Customer Distribution ..... 62

25

## 行业评价和报道

Industry Evaluation And Reporting ..... 63

## 企业简介 Company Introduction

江苏安德信加速器有限公司（简称：安德信科技）是一家专业从事带电粒子加速器及其部件、束测仪器、真空馈通(FT)、真空观察窗(VOW)、真空隔离器(VI)及相关设备研发与制造的高新技术企业。公司通过了ISO9001质量管理体系认证，是包括中核集团等在内的数十家企业合格供应商，上海硬X射线自由电子激光装置项目优秀设备研制供应商，是中央电视台《强国智造》栏目展播企业。公司技术团队由国家特聘专家、俄罗斯自然科学院院士、教授与研究员、副教授与高级工程师等组成。

公司成立以来，在离子源、超导腔、常温谐振腔、电子源及40余种不同型号的束流位置探测器（BBPM、BAM、CBPM、SBPM、低温BPM）、荧光靶、法拉第筒、发射度测量仪、ACCT、真空馈通、真空观察窗、真空隔离器等产品的设计、生产制造方面积累了丰富的经验，能够为用户提供全面的服务。经过多年的研发及市场培育和拓展，公司的产品质量和服务得到了客户的广泛认可和高度评价。产品已经由美国、法国、德国、英国、俄罗斯、中国等多国近百家科研院、所、大学以及数千家企业使用，完全满足技术要求，性能稳定，达到国际领先水平。

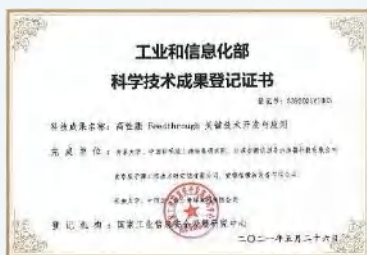

## 企业简介 Company Introduction

Jiangsu ANDESUN Accelerator Co., Ltd. (Abbreviation: ANDESUN Technology) is a high-tech enterprise specializing in the R&D and manufacturing of **charged-particle accelerators** and their components, **beam-measurement instruments**, **feedthroughs (FT)**, **vacuum observation windows (VOW)**, **vacuum isolators (VI)** and their related equipment. ANDESUN Technology has passed the **ISO9001** quality management system certification, and is a qualified supplier to dozens of companies including China National Nuclear Corporation etc.. ANDESUN Technology is an **Excellent Equipment Development Supplier** for the Shanghai High repetition rate XFEL and Extreme light facility (**SHINE**), and is a **Media Exhibition Enterprise** of CCTV's "**Strong Nation Intelligent Manufacturing**" column. The company's core tech team is made up of nationally appointed experts, Russian Academy of Natural Sciences members, professors, researchers, associate professors and senior engineers.

Since the establishment of ANDESUN Technology, the company has accumulated rich experience in the design and manufacturing of **ion sources**, **superconducting RF cavities**, **room-temperature RF cavities**, electron accelerators and more than 40 different types of **Beam Position Monitors** (including **BBPM**, **BAM**, **CBPM**, **SBPM**, **low-temperature BPM**), **Profile-monitors**, **Faraday-Cups**, **Emittance-scanners**, **ACCT**, **feedthroughs**, **Vacuum Observation Windows**, **Vacuum Isolators** and other products, and is able to provide users with comprehensive services. After years of R&D and market cultivation and expansion, the ANDESUN's product quality and services have been widely recognized and highly praised by customers. The products have been used by nearly a hundred scientific research **institutes & universities** and thousands of companies in the **United States**, **France**, **Germany**, **the United Kingdom**, **Russia**, **China** and other countries. The products can fully meet the technical requirements, have stable performance, and have reached the international leading level.

## 产品简介 Product Introduction

馈通（Feedthrough）是一种可以穿过真空腔壁，在大气与真空间进行直流、射频（微波）和光信号传输的密封装置。安德信科技真空馈通广泛应用在核电工程、带电粒子加速器、真空设备（真空泵、真空计、检漏仪、真空室、真空盒等）、半导体（镀膜与光刻）设备、真空镀膜设备、低温（低温制备、超导）系统、医疗设备、航空航天、石油勘探等领域，是支撑这些领域研发与生产的相关器件和装备的关键部件。

安德信科技研制生产的高性能馈通与真空观察窗，经过超高真空、超高温、极限低温、高气压、高电压、高电流、微波性能等一系列测试，馈通接插次数超过20000次，内芯承受拉力超过100N，产品插入损耗低，性能稳定，质量过硬，可以适用于多种环境，已服务于数千家科研单位与企业。

ANDESUN Technology's feedthroughs have been widely used in nuclear power engineering, charged-particle accelerators, vacuum equipment (vacuum pumps, vacuum gauges, leak detectors, vacuum chambers, etc.), semiconductor (coating and photolithography) equipment, vacuum coating equipment, low-temperature (cryogenic preparation, superconducting) systems, medical equipment, aerospace, oil exploration and other fields. It is a key component of related devices and equipment supporting the R&D and production in these fields.

The high-performance multipin and coaxial vacuum connector jointly developed and produced by ANDESUN TECHNOLOGY has undergone a series of tests including ultra-high vacuum, ultra-high temperature, low temperature, high pressure, high voltage, high current, microwave performance, plug in more than 20000 times etc. The product has low insertion loss, stable performance, and excellent quality, and can be used in various environments. The feedthroughs supplied by ANDESUN have serviced over 1000 users.

产品结构：由单针或多针内导体、绝缘支撑且隔离真空的介质、接地或屏蔽的外壳组成。

Product structure: Composed of a single or multiple needle inner conductor, an insulated and vacuum isolated medium, and a grounded or shielded outer shell.

材质选择：内外导体可选可伐、不锈钢、钛、无氧铜等；介质材料可选陶瓷、玻璃、蓝宝石、金刚石等。

Material selection: The inner and outer conductors can be selected from materials such as kovar, stainless steel, titanium, oxygen-free copper, etc; The medium materials can be ceramic, glass, sapphire, diamond, etc.

技术原理：通过金属和介质组成同轴结构，在机械结构合理的前提下，调节结构不连续导致的传输阻抗突变来实现大的传输带宽。

Technical principle: A resonant cavity filter is composed of metal, ceramics, vacuum, and other media to achieve a large transmission bandwidth by harmonizing the transmission impedance changes caused by medium and structural changes.

焊接方式：在炉中气氛或者真空环境下钎焊达到高真空密封。

Welding method: Braze in the furnace atmosphere or vacuum environment to achieve high vacuum sealing.

## 同轴 2.92 型系列 Coaxial 2.92 Series

同轴2.92型馈通用于在大气和真空间传输直流或高频信号，两端为标准2.92型射频接口，也可以根据用户需求，一端为光杆、内螺纹、外螺纹或BPM Button。根据用户需要，外导体可以为其焊接CF法兰，KF法兰，非标法兰等。

Coaxial 2.92-type feedthrough is used to transmit DC or RF signals between the atmosphere and vacuum. Both ends of the feedthrough is the standard 2.92-type port. Depending on user requirements, one end can be a rod, internal thread-structure, outer thread-structure, or BPM Button, while the outer conductor can be welded with the CF flange, KF flange, non-standard flange, according to user's need.

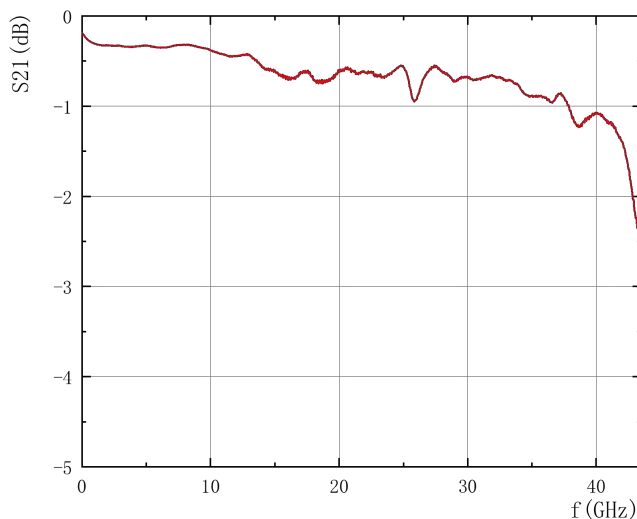

插入损耗 Insertion Loss S21  
(标识代号 identification code: IL-292-A)

### ADS-FT-D292-001

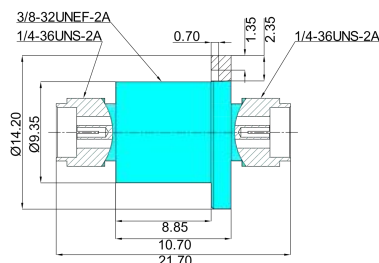

#### 技术参数 Specification

封接方式 Sealing Form	陶瓷钎焊 Ceramic Brazing
端口标准 Port Standards	2.92
最大电流 Max Current	1.5 A
最大电压 Max Voltage	0.5 KV
工作频率 Working Frequency	0~40 GHz (IL-292-A)
插损 Insertion Loss	≤1.5 dB
端口阻抗 Port Impedance	50 ± 3 Ω
漏气率 Leakage Rate	≤5 × 10 <sup>-13</sup> Pa·m <sup>3</sup> /s
耐温 Temperature Resistance	-271°C~600 °C
耐气压 Pressure Tolerance	10 Bar
金属材料 Metal Material	可伐/不锈钢/钛 Kovar/SS/Titanium

## 同轴 SMA 型系列 Coaxial SMA Series

同轴SMA型馈通用于在大气和真空间传输直流或高频信号，两端为标准SMA型射频接口，也可以根据用户需求，一端为光杆、内螺纹、外螺纹或BPM Button。根据用户需要，外导体可以为其焊接CF法兰，KF法兰，非标法兰等。

Coaxial SMA-type feedthrough is used to transmit DC or RF signals between the atmosphere and vacuum. Both ends of the feedthrough is the standard SMA-type port. Depending on user requirements, one end can be a rod, internal thread-structure, outer thread-structure, or BPM Button, while the outer conductor can be welded with the CF flange, KF flange, non-standard flange, according to user's need.

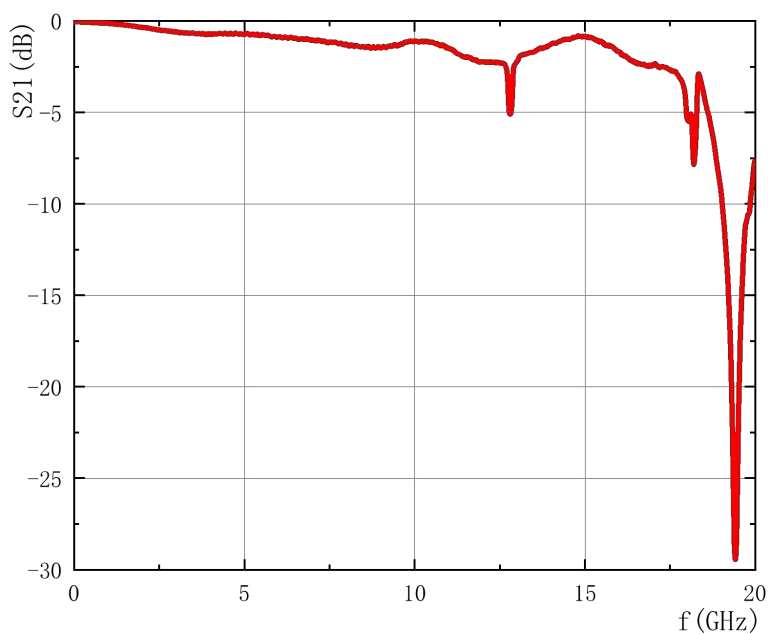

插入损耗 Insertion Loss S21  
(标识代号 identification code: IL-SMA-A)

## 同轴 SMA 型系列 Coaxial SMA Series

### ADS-FT-SMA-002

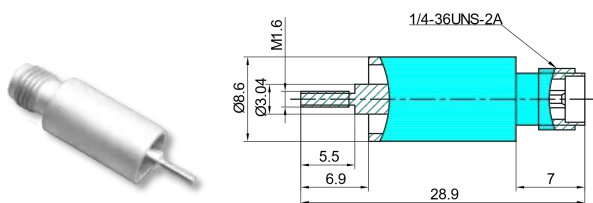

#### 技术参数 Specification

封接方式 Sealing Form	陶瓷钎焊 Ceramic Brazing
端口标准 Port Standards	SMA-K 外螺纹 External screw
最大电流 Max Current	5 A
最大电压 Max Voltage	1.5 KV
工作频率 Working Frequency	0~8.0 GHz (IL-SMA-A)
插损 Insertion Loss	≤1.5 dB
端口阻抗 Port Impedance	50 ± 3 Ω
漏气率 Leakage Rate	≤5 × 10 <sup>-13</sup> Pa·m <sup>3</sup> /s
耐温 Temperature Resistance	-271°C~600 °C
耐气压 Pressure Tolerance	10 Bar
金属材料 Material	可伐/不锈钢 Kovar/SS

### ADS-FT-SMA-003

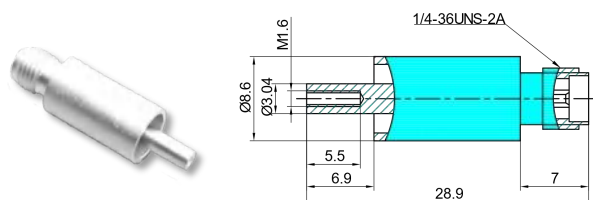

#### 技术参数 Specification

封接方式 Sealing Form	陶瓷钎焊 Ceramic Brazing
端口标准 Port Standards	SMA-K 内螺纹 Internal screw
最大电流 Max Current	5 A
最大电压 Max Voltage	1.5 KV
工作频率 Working Frequency	0~8.0 GHz (IL-SMA-A)
插损 Insertion Loss	≤1.5 dB
端口阻抗 Port Impedance	50 ± 3 Ω
漏气率 Leakage Rate	≤5 × 10 <sup>-13</sup> Pa·m <sup>3</sup> /s
耐温 Temperature Resistance	-271°C~600 °C
耐气压 Pressure Tolerance	10 Bar
金属材料 Material	可伐/不锈钢 Kovar/SS

### ADS-FT-DSMA-001

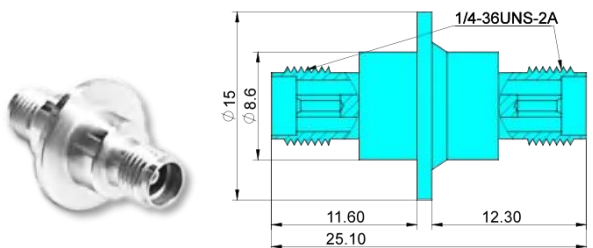

#### 技术参数 Specification

封接方式 Sealing Form	陶瓷钎焊 Ceramic Brazing
端口标准 Port Standards	SMA-K SMA-K
最大电流 Max Current	5 A
最大电压 Max Voltage	1.5 KV
工作频率 Working Frequency	0~8 GHz (IL-SMA-A)
插损 Insertion Loss	≤1.5 dB
端口阻抗 Port Impedance	50 ± 3 Ω
漏气率 Leakage Rate	≤5 × 10 <sup>-13</sup> Pa·m <sup>3</sup> /s
耐温 Temperature Resistance	-271°C~600 °C
耐气压 Pressure Tolerance	10 Bar
金属材料 Material	可伐/不锈钢 Kovar/SS

## 同轴 SMA 型系列 Coaxial SMA Series

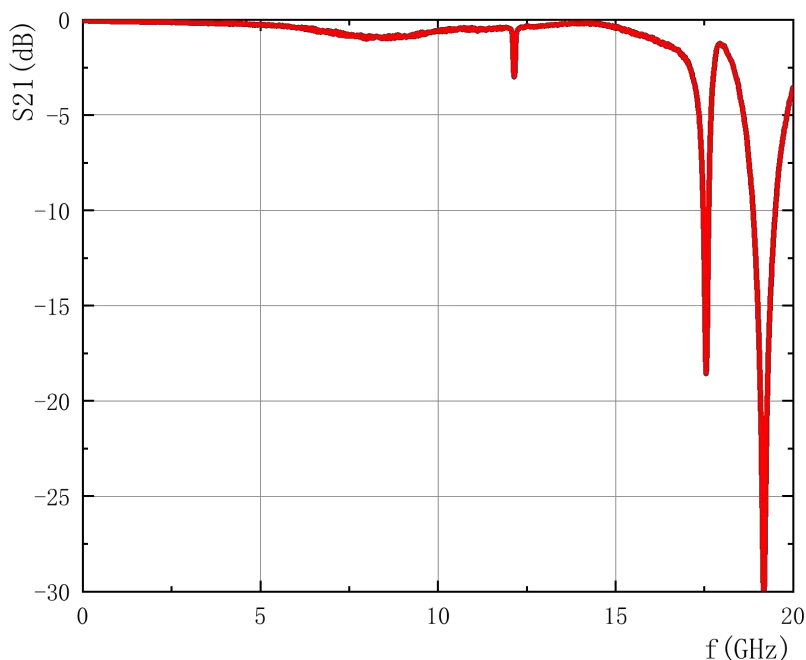

插入损耗 Insertion Loss S21  
(标识代号 identification code: IL-SMA-B)

### ADS-FT-SMA-RPL-008-37.5-11.5GHz

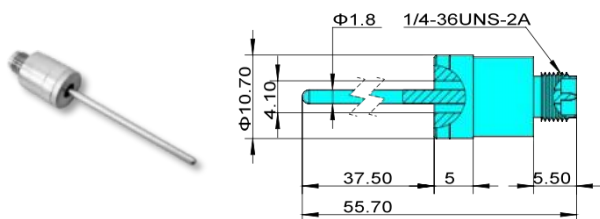

#### 技术参数 Specification

封接方式 Sealing Form	陶瓷钎焊 Ceramic Brazing
端口标准 Port Standards	SMA-RP-J 光杆 Rod
最大电流 Max Current	5 A
最大电压 Max Voltage	2.5 KV
工作频率 Working Frequency	0~11.5 GHz (IL-SMA-B)
插损 Insertion Loss	≤1.2 dB
端口阻抗 Port Impedance	50 ± 3 Ω
漏气率 Leakage Rate	≤5 × 10 <sup>-13</sup> Pa·m <sup>3</sup> /s
耐温 Temperature Resistance	-271°C~600 °C
耐气压 Pressure Tolerance	10 Bar
金属材料 Material	可伐/不锈钢 Kovar/SS

### ADS-FT-SMA-RPL-009-37.5-11.5GHz

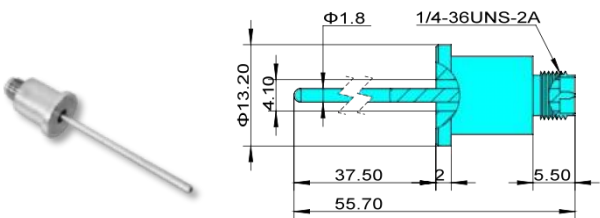

#### 技术参数 Specification

封接方式 Sealing Form	陶瓷钎焊 Ceramic Brazing
端口标准 Port Standards	SMA-RP-J 光杆 Rod
最大电流 Max Current	5 A
最大电压 Max Voltage	2.5 KV
工作频率 Working Frequency	0~11.5 GHz (IL-SMA-B)
插损 Insertion Loss	≤1.2 dB
端口阻抗 Port Impedance	50 ± 3 Ω
漏气率 Leakage Rate	≤5 × 10 <sup>-13</sup> Pa·m <sup>3</sup> /s
耐温 Temperature Resistance	-271°C~600 °C
耐气压 Pressure Tolerance	10 Bar
金属材料 Material	可伐/不锈钢 Kovar/SS

## 同轴 SMA 型系列 Coaxial SMA Series

### ADS-FT-SMA-009-11.5GHz

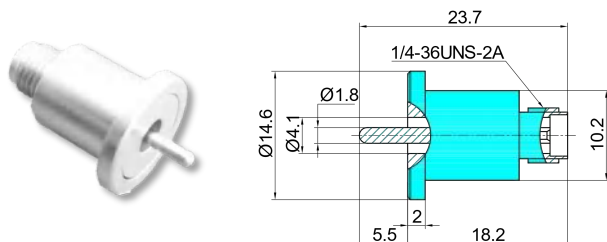

#### 技术参数 Specification

封接方式 Sealing Form	陶瓷钎焊 Ceramic Brazing
端口标准 Port Standards	SMA-K 光杆 Rod
最大电流 Max Current	5 A
最大电压 Max Voltage	2.5 KV
工作频率 Working Frequency	0~11.5 GHz (IL-SMA-B)
插损 Insertion Loss	≤1.2 dB
端口阻抗 Port Impedance	50 ± 3 Ω
漏气率 Leakage Rate	≤5 × 10 <sup>-13</sup> Pa·m <sup>3</sup> /s
耐温 Temperature Resistance	-271°C~600 °C
耐气压 Pressure Tolerance	10 Bar
金属材料 Material	可伐/不锈钢 Kovar/SS

### ADS-FT-SMA-RP-009-11.5GHz

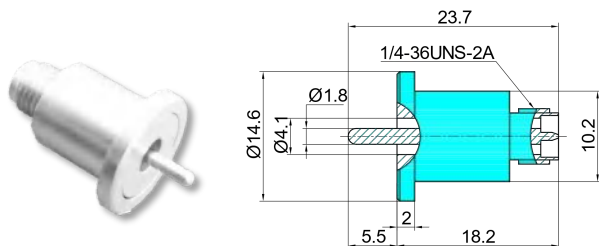

#### 技术参数 Specification

封接方式 Sealing Form	陶瓷钎焊 Ceramic Brazing
端口标准 Port Standards	SMA-RP-J 光杆 Rod
最大电流 Max Current	5 A
最大电压 Max Voltage	2.5 KV
工作频率 Working Frequency	0~11.5 GHz (IL-SMA-B)
插损 Insertion Loss	≤1.2 dB
端口阻抗 Port Impedance	50 ± 3 Ω
漏气率 Leakage Rate	≤5 × 10 <sup>-13</sup> Pa·m <sup>3</sup> /s
耐温 Temperature Resistance	-271°C~600 °C
耐气压 Pressure Tolerance	10 Bar
金属材料 Material	可伐/不锈钢 Kovar/SS

### ADS-FT-SMA-BRP-010-11.5GHz

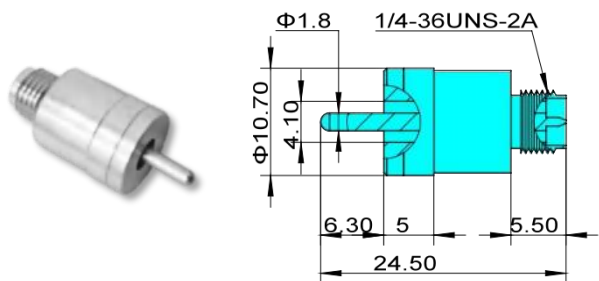

#### 技术参数 Specification

封接方式 Sealing Form	陶瓷钎焊 Ceramic Brazing
端口标准 Port Standards	SMA-RP-J 光杆 Rod
最大电流 Max Current	5 A
最大电压 Max Voltage	2.5 KV
工作频率 Working Frequency	0~11.5 GHz (IL-SMA-B)
插损 Insertion Loss	≤1.2 dB
端口阻抗 Port Impedance	50 ± 3 Ω
漏气率 Leakage Rate	≤5 × 10 <sup>-13</sup> Pa·m <sup>3</sup> /s
耐温 Temperature Resistance	-271°C~600 °C
耐气压 Pressure Tolerance	10 Bar
金属材料 Material	可伐/不锈钢 Kovar/SS

### ADS-FT-SMA-J-001-11.5GHz

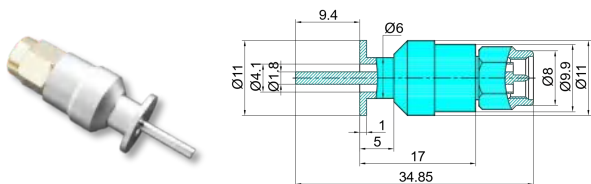

#### 技术参数 Specification

封接方式 Sealing Form	陶瓷钎焊 Ceramic Brazing
端口标准 Port Standards	SMA-J 光杆 Rod
最大电流 Max Current	5 A
最大电压 Max Voltage	2.5 KV
工作频率 Working Frequency	0~11.5 GHz (IL-SMA-B)
插损 Insertion Loss	≤1.2 dB
端口阻抗 Port Impedance	50 ± 3 Ω
漏气率 Leakage Rate	≤5 × 10 <sup>-13</sup> Pa·m <sup>3</sup> /s
耐温 Temperature Resistance	-271°C~600 °C
耐气压 Pressure Tolerance	10 Bar
金属材料 Material	可伐/不锈钢 Kovar/SS

## 同轴 SMA 型系列 Coaxial SMA Series

### ADS-FT-DSMA-002-11.5GHz

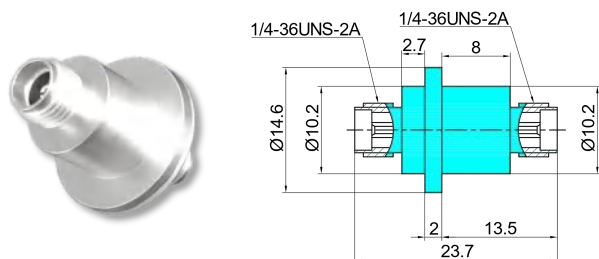

#### 技术参数 Specification

封接方式 Sealing Form	陶瓷钎焊 Ceramic Brazing
端口标准 Port Standards	SMA-K
最大电流 Max Current	5 A
最大电压 Max Voltage	2.5 KV
工作频率 Working Frequency	0~11.5 GHz (IL-SMA-B)
插损 Insertion Loss	≤1.2 dB
端口阻抗 Port Impedance	50±3 Ω
漏气率 Leakage Rate	≤5×10 <sup>-13</sup> Pa·m <sup>3</sup> /s
耐温 Temperature Resistance	-271°C~600 °C
耐气压 Pressure Tolerance	10 Bar
金属材料 Material	可伐/不锈钢 Kovar/SS

### ADS-FT-DSMA-002-11.5GHz-CF25

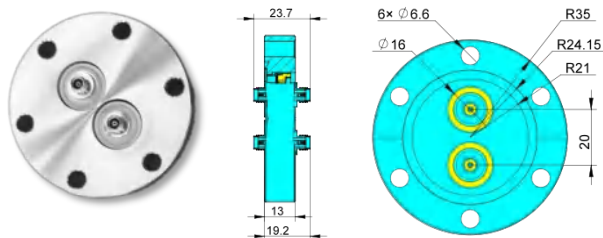

#### 技术参数 Specification

封接方式 Sealing Form	陶瓷钎焊 Ceramic Brazing
端口标准 Port Standards	SMA-K
最大电流 Max Current	5 A
最大电压 Max Voltage	2.5 KV
工作频率 Working Frequency	0~11.5 GHz (IL-SMA-B)
插损 Insertion Loss	≤1.2 dB
端口阻抗 Port Impedance	50±3 Ω
漏气率 Leakage Rate	≤5×10 <sup>-13</sup> Pa·m <sup>3</sup> /s
耐温 Temperature Resistance	-40°C~300°C
耐气压 Pressure Tolerance	10 Bar
金属材料 Material	可伐/不锈钢 Kovar/SS

## 同轴 SMA 型系列 Coaxial SMA Series

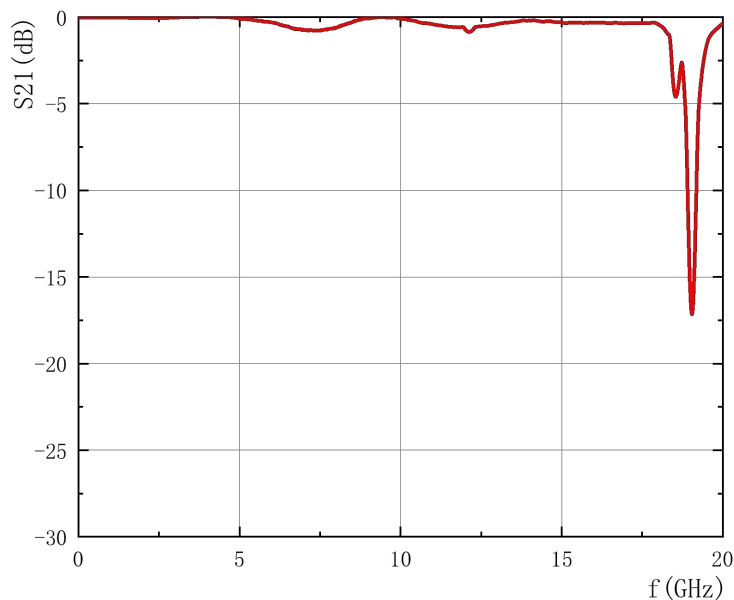

定制版插入损耗 Customized Insertion Loss S21  
(标识代号 identification code: IL-SMA-C)

### ADS-FT-SMA-RP-008-37.5-17GHz

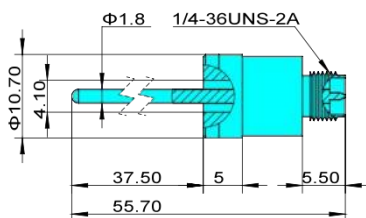

#### 技术参数 Specification

封接方式 Sealing Form	陶瓷钎焊 Ceramic Brazing
端口标准 Port Standards	SMA-RP-J 光杆 Rod
最大电流 Max Current	5 A
最大电压 Max Voltage	2.5 KV
工作频率 Working Frequency	0~17 GHz (IL-SMA-C)
插损 Insertion Loss	$\leq 1.2$ dB
端口阻抗 Port Impedance	$50 \pm 3 \Omega$
漏气率 Leakage Rate	$\leq 5 \times 10^{-13}$ Pa·m <sup>3</sup> /s
耐温 Temperature Resistance	-271°C~600 °C
耐气压 Pressure Tolerance	10 Bar
金属材料 Material	可伐/不锈钢 Kovar/SS

### ADS-FT-SMA-RP-009-37.5-17GHz

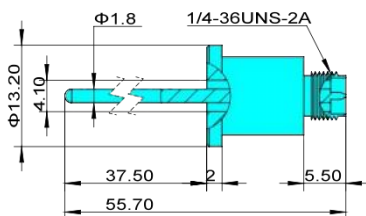

#### 技术参数 Specification

封接方式 Sealing Form	陶瓷钎焊 Ceramic Brazing
端口标准 Port Standards	SMA-RP-J 光杆 Rod
最大电流 Max Current	5 A
最大电压 Max Voltage	2.5 KV
工作频率 Working Frequency	0~17 GHz (IL-SMA-C)
插损 Insertion Loss	$\leq 1.2$ dB
端口阻抗 Port Impedance	$50 \pm 3 \Omega$
漏气率 Leakage Rate	$\leq 5 \times 10^{-13}$ Pa·m <sup>3</sup> /s
耐温 Temperature Resistance	-271°C~600 °C
耐气压 Pressure Tolerance	10 Bar
金属材料 Material	可伐/不锈钢 Kovar/SS

## 同轴 SMA 型系列 Coaxial SMA Series

### ADS-FT-SMA-009-17GHz

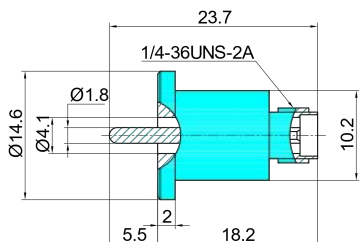

#### 技术参数 Specification

封接方式 Sealing Form	陶瓷钎焊 Ceramic Brazing
端口标准 Port Standards	SMA-K 光杆 Rod
最大电流 Max Current	5 A
最大电压 Max Voltage	2.5 KV
工作频率 Working Frequency	0~17 GHz (IL-SMA-C)
插损 Insertion Loss	≤1.2 dB
端口阻抗 Port Impedance	50±3 Ω
漏气率 Leakage Rate	≤5×10 <sup>-13</sup> Pa·m <sup>3</sup> /s
耐温 Temperature Resistance	-271°C~600 °C
耐气压 Pressure Tolerance	10 Bar
金属材料 Material	可伐/不锈钢 Kovar/SS

### ADS-FT-SMA-RP-009-17GHz

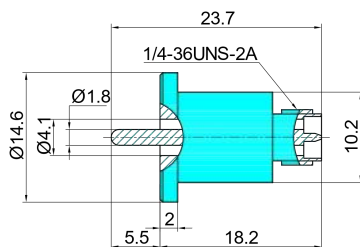

#### 技术参数 Specification

封接方式 Sealing Form	陶瓷钎焊 Ceramic Brazing
端口标准 Port Standards	SMA-RP-J 光杆 Rod
最大电流 Max Current	5 A
最大电压 Max Voltage	2.5 KV
工作频率 Working Frequency	0~17 GHz (IL-SMA-C)
插损 Insertion Loss	≤1.2 dB
端口阻抗 Port Impedance	50±3 Ω
漏气率 Leakage Rate	≤5×10 <sup>-13</sup> Pa·m <sup>3</sup> /s
耐温 Temperature Resistance	-271°C~600 °C
耐气压 Pressure Tolerance	10 Bar
金属材料 Material	可伐/不锈钢 Kovar/SS

### ADS-FT-SMA-BRP-010-17GHz

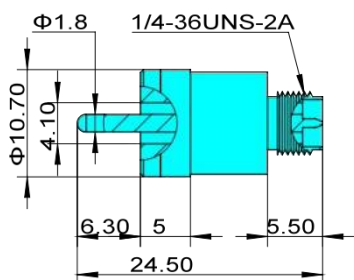

#### 技术参数 Specification

封接方式 Sealing Form	陶瓷钎焊 Ceramic Brazing
端口标准 Port Standards	SMA-RP-J 光杆 Rod
最大电流 Max Current	5 A
最大电压 Max Voltage	2.5 KV
工作频率 Working Frequency	0~17 GHz (IL-SMA-C)
插损 Insertion Loss	≤1.2 dB
端口阻抗 Port Impedance	50±3 Ω
漏气率 Leakage Rate	≤5×10 <sup>-13</sup> Pa·m <sup>3</sup> /s
耐温 Temperature Resistance	-271°C~600 °C
耐气压 Pressure Tolerance	10 Bar
金属材料 Material	可伐/不锈钢 Kovar/SS

### ADS-FT-SMA-J-001-17GHz

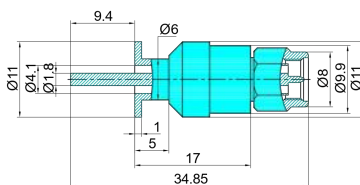

#### 技术参数 Specification

封接方式 Sealing Form	陶瓷钎焊 Ceramic Brazing
端口标准 Port Standards	SMA-J 光杆 Rod
最大电流 Max Current	5 A
最大电压 Max Voltage	2.5 KV
工作频率 Working Frequency	0~17 GHz (IL-SMA-C)
插损 Insertion Loss	≤1.2 dB
端口阻抗 Port Impedance	50±3 Ω
漏气率 Leakage Rate	≤5×10 <sup>-13</sup> Pa·m <sup>3</sup> /s
耐温 Temperature Resistance	-271°C~600 °C
耐气压 Pressure Tolerance	10 Bar
金属材料 Material	可伐/不锈钢 Kovar/SS

## 同轴 SMA 型系列 Coaxial SMA Series

### ADS-FT-DSMA-002-17GHz

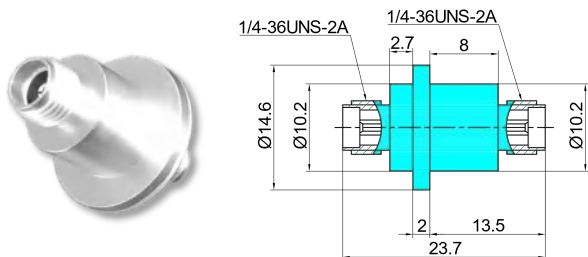

#### 技术参数 Specification

封接方式 Sealing Form	陶瓷钎焊 Ceramic Brazing
端口标准 Port Standards	SMA-K SMA-K
最大电流 Max Current	5 A
最大电压 Max Voltage	2.5 KV
工作频率 Working Frequency	0~17 GHz (IL-SMA-C)
插损 Insertion Loss	≤1.2 dB
端口阻抗 Port Impedance	50 ± 3 Ω
漏气率 Leakage Rate	≤5 × 10 <sup>-13</sup> Pa·m <sup>3</sup> /s
耐温 Temperature Resistance	-271°C~600 °C
耐气压 Pressure Tolerance	10 Bar
金属材料 Material	可伐/不锈钢 Kovar/SS

### ADS-FT-DSMA-002-17GHz-CF25

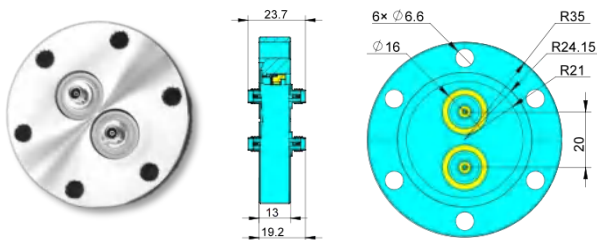

#### 技术参数 Specification

封接方式 Sealing Form	陶瓷钎焊 Ceramic Brazing
端口标准 Port Standards	SMA-K SMA-K
最大电流 Max Current	5 A
最大电压 Max Voltage	2.5 KV
工作频率 Working Frequency	0~17 GHz (IL-SMA-C)
插损 Insertion Loss	≤1.2 dB
端口阻抗 Port Impedance	50 ± 3 Ω
漏气率 Leakage Rate	≤5 × 10 <sup>-13</sup> Pa·m <sup>3</sup> /s
耐温 Temperature Resistance	-40°C~300°C
耐气压 Pressure Tolerance	10 Bar
金属材料 Material	可伐/不锈钢 Kovar/SS

## 同轴 N 型系列 Coaxial N Series

同轴N型馈通用于在大气和真空间传输直流或高频信号，两端为标准N型射频接口，也可以根据用户需求，一端为光杆、内螺纹、外螺纹或BPM Button。根据用户需要，外导体可以为其焊接CF法兰，KF法兰，非标法兰等。

Coaxial N-type feedthrough is used to transmit DC or RF signals between the atmosphere and vacuum. Both ends of the feedthrough is the standard N-type port. Depending on user requirements, one end can be a rod, internal thread-structure, outer thread-structure, or BPM Button, while the outer conductor can be welded with the CF flange, KF flange, non-standard flange, according to user's need.

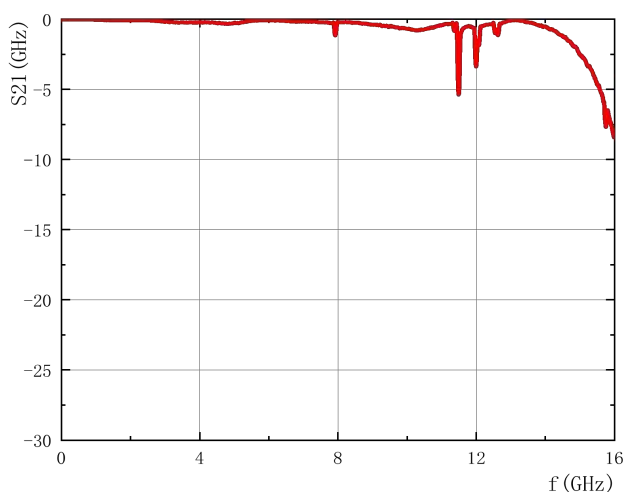

插入损耗 Insertion Loss S21  
(标识代号 identification code: IL-N-A)

### ADS-FT-N-001

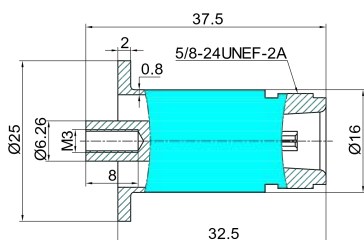

#### 技术参数 Specification

封接方式 Sealing Form	陶瓷钎焊 Ceramic Brazing
端口标准 Port Standards	N-K 内螺纹 Internal thread
最大电流 Max Current	10 A
最大电压 Max Voltage	3.5 KV
工作频率 Working Frequency	0~7.5 GHz (IL-N-A)
插损 Insertion Loss	≤0.6 dB
端口阻抗 Port Impedance	50 ± 3 Ω
漏气率 Leakage Rate	≤5 × 10 <sup>-13</sup> Pa·m <sup>3</sup> /s
耐温 Temperature Resistance	-271°C~600 °C
耐气压 Pressure Tolerance	10 Bar
金属材料 Material	可伐/不锈钢 Kovar/SS

## 同轴 N 型系列 Coaxial N Series

### ADS-FT-N-002

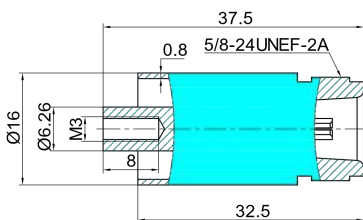

#### 技术参数 Specification

封接方式 Sealing Form	陶瓷钎焊 Ceramic Brazing
端口标准 Port Standards	N-K 内螺纹 Internal thread
最大电流 Max Current	10 A
最大电压 Max Voltage	3.5 KV
工作频率 Working Frequency	0~7.5 GHz (IL-N-A)
插损 Insertion Loss	≤0.6 dB
端口阻抗 Port Impedance	50 ± 3 Ω
漏气率 Leakage Rate	≤5 × 10 <sup>-13</sup> Pa·m <sup>3</sup> /s
耐温 Temperature Resistance	-271°C~600 °C
耐气压 Pressure Tolerance	10 Bar
金属材料 Material	可伐/不锈钢 Kovar/SS

### ADS-FT-N-003

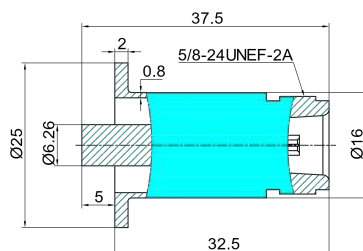

#### 技术参数 Specification

封接方式 Sealing Form	陶瓷钎焊 Ceramic Brazing
端口标准 Port Standards	N-K 光杆 Rod
最大电流 Max Current	10 A
最大电压 Max Voltage	3.5 KV
工作频率 Working Frequency	0~7.5 GHz (IL-N-A)
插损 Insertion Loss	≤0.6 dB
端口阻抗 Port Impedance	50 ± 3 Ω
漏气率 Leakage Rate	≤5 × 10 <sup>-13</sup> Pa·m <sup>3</sup> /s
耐温 Temperature Resistance	-271°C~600 °C
耐气压 Pressure Tolerance	10 Bar
金属材料 Material	可伐/不锈钢 Kovar/SS

### ADS-FT-N-004

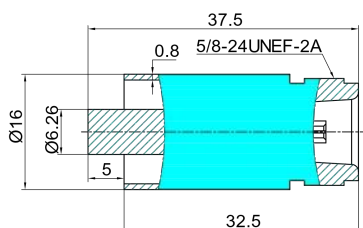

#### 技术参数 Specification

封接方式 Sealing Form	陶瓷钎焊 Ceramic Brazing
端口标准 Port Standards	N-K 光杆 Rod
最大电流 Max Current	10 A
最大电压 Max Voltage	3.5 KV
工作频率 Working Frequency	0~7.5 GHz (IL-N-A)
插损 Insertion Loss	≤0.6 dB
端口阻抗 Port Impedance	50 ± 3 Ω
漏气率 Leakage Rate	≤5 × 10 <sup>-13</sup> Pa·m <sup>3</sup> /s
耐温 Temperature Resistance	-271°C~600 °C
耐气压 Pressure Tolerance	10 Bar
金属材料 Material	可伐/不锈钢 Kovar/SS

### ADS-FT-N-005

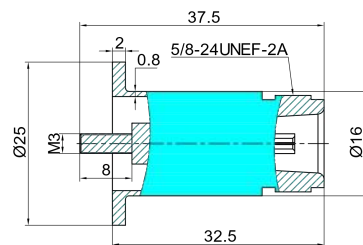

#### 技术参数 Specification

封接方式 Sealing Form	陶瓷钎焊 Ceramic Brazing
端口标准 Port Standards	N-K 外螺纹 External thread
最大电流 Max Current	10 A
最大电压 Max Voltage	3.5 KV
工作频率 Working Frequency	0~7.5 GHz (IL-N-A)
插损 Insertion Loss	≤0.6 dB
端口阻抗 Port Impedance	50 ± 3 Ω
漏气率 Leakage Rate	≤5 × 10 <sup>-13</sup> Pa·m <sup>3</sup> /s
耐温 Temperature Resistance	-271°C~600 °C
耐气压 Pressure Tolerance	10 Bar
金属材料 Material	可伐/不锈钢 Kovar/SS

## 同轴 N 型系列 Coaxial N Series

### ADS-FT-N-006

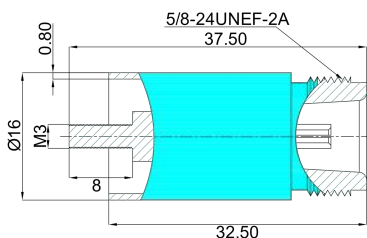

#### 技术参数 Specification

封接方式 Sealing Form	陶瓷钎焊 Ceramic Brazing
端口标准 Port Standards	N-K 外螺纹 Internal thread
最大电流 Max Current	10 A
最大电压 Max Voltage	3.5 KV
工作频率 Working Frequency	0~7.5 GHz (IL-N-A)
插损 Insertion Loss	≤0.6 dB
端口阻抗 Port Impedance	50 ± 3 Ω
漏气率 Leakage Rate	≤5 × 10 <sup>-13</sup> Pa·m <sup>3</sup> /s
耐温 Temperature Resistance	-271°C~600 °C
耐气压 Pressure Tolerance	10 Bar
金属材料 Material	可伐/不锈钢 Kovar/SS

### ADS-FT-NN-002

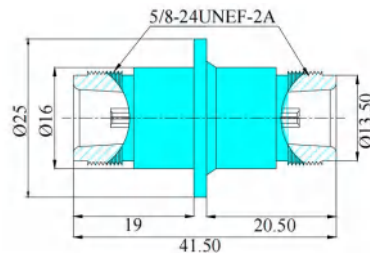

#### 技术参数 Specification

封接方式 Sealing Form	陶瓷钎焊 Ceramic Brazing
端口标准 Port Standards	N-K N-K
最大电流 Max Current	10 A
最大电压 Max Voltage	3.5 KV
工作频率 Working Frequency	0~7.5 GHz (IL-N-A)
插损 Insertion Loss	≤0.6 dB
端口阻抗 Port Impedance	50 ± 3 Ω
漏气率 Leakage Rate	≤5 × 10 <sup>-13</sup> Pa·m <sup>3</sup> /s
耐温 Temperature Resistance	-271°C~600 °C
耐气压 Pressure Tolerance	10 Bar
金属材料 Material	可伐/不锈钢 Kovar/SS

### ADS-FT-NN-002-KF40

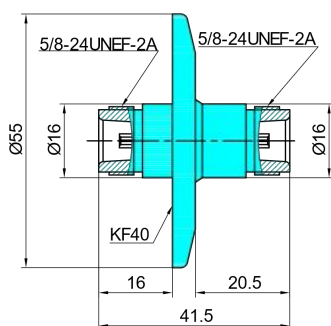

#### 技术参数 Specification

封接方式 Sealing Form	陶瓷钎焊 Ceramic Brazing
端口标准 Port Standards	N-K N-K
最大电流 Max Current	10 A
最大电压 Max Voltage	3.5 KV
工作频率 Working Frequency	0~7.5 GHz (IL-N-A)
插损 Insertion Loss	≤0.6 dB
端口阻抗 Port Impedance	50 ± 3 Ω
漏气率 Leakage Rate	≤5 × 10 <sup>-13</sup> Pa·m <sup>3</sup> /s
耐温 Temperature Resistance	-271°C~600 °C
耐气压 Pressure Tolerance	10 Bar
金属材料 Material	可伐/不锈钢 Kovar/SS

### ADS-FT-N-CF16-SL

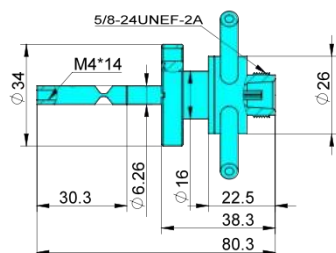

#### 技术参数 Specification

封接方式 Sealing Form	陶瓷钎焊 Ceramic Brazing
端口标准 Port Standards	N-K 内螺纹 Internal thread
最大电流 Max Current	10 A
最大电压 Max Voltage	3.5 KV
工作频率 Working Frequency	0~7.5 GHz (IL-N-A)
插损 Insertion Loss	≤0.6 dB
端口阻抗 Port Impedance	50 ± 3 Ω
漏气率 Leakage Rate	≤5 × 10 <sup>-13</sup> Pa·m <sup>3</sup> /s
耐温 Temperature Resistance	-40°C~300 °C
耐气压 Pressure Tolerance	10 Bar
冷却方式 Cooling Method	纯水 Pure Water
金属材料 Material	可伐/不锈钢 Kovar/SS

## 同轴 N 型系列 Coaxial N Series

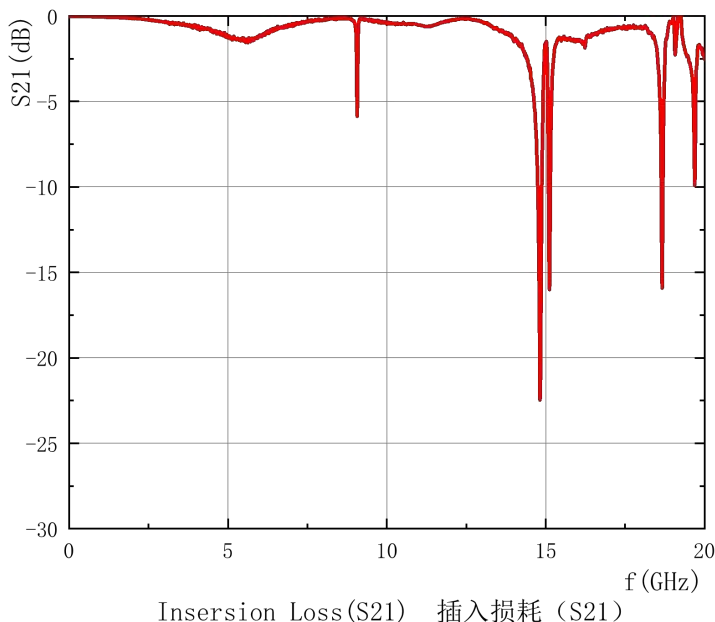

(标识代号 identification code: IL-N-B)

### ADS-FT-N-FL-007

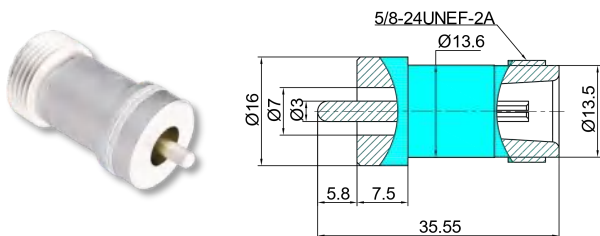

#### 技术参数 Specification

封接方式 Sealing Form	陶瓷钎焊 Ceramic Brazing
端口标准 Port Standards	N-K 光杆 Rod
最大电流 Max Current	10 A
最大电压 Max Voltage	3.5 KV
工作频率 Working Frequency	0~8.5 GHz (IL-N-B)
插损 Insertion Loss	≤1.6 dB
端口阻抗 Port Impedance	50 ± 3 Ω
漏气率 Leakage Rate	≤5 × 10 <sup>-13</sup> Pa·m <sup>3</sup> /s
耐温 Temperature Resistance	-271°C~600 °C
耐气压 Pressure Tolerance	10 Bar
金属材料 Material	可伐/不锈钢 Kovar/SS

### ADS-FT-NN-FL-003

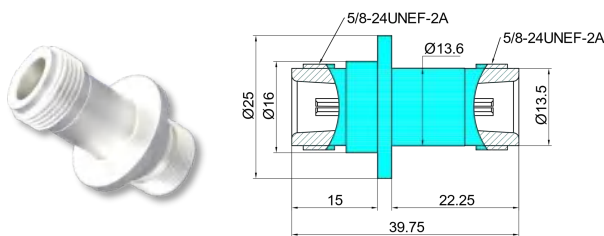

#### 技术参数 Specification

封接方式 Sealing Form	陶瓷钎焊 Ceramic Brazing
端口标准 Port Standards	N-K N-K
最大电流 Max Current	10 A
最大电压 Max Voltage	3.5 KV
工作频率 Working Frequency	0~8.5 GHz (IL-N-B)
插损 Insertion Loss	≤1.6 dB
端口阻抗 Port Impedance	50 ± 3 Ω
漏气率 Leakage Rate	≤5 × 10 <sup>-13</sup> Pa·m <sup>3</sup> /s
耐温 Temperature Resistance	-271°C~600 °C
耐气压 Pressure Tolerance	10 Bar
金属材料 Material	可伐/不锈钢 Kovar/SS

## 同轴 N 型系列 Coaxial N Series

### ADS-FT-N-FL-R

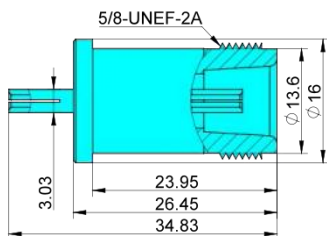

#### 技术参数 Specification

封接方式 Sealing Form	陶瓷钎焊 Ceramic Brazing
端口标准 Port Standards	N-K 插孔 Socket
最大电流 Max Current	10 A
最大电压 Max Voltage	3.5 KV
工作频率 Working Frequency	0~8.5 GHz (IL-N-B)
插损 Insertion Loss	≤1.6 dB
端口阻抗 Port Impedance	50±3 Ω
漏气率 Leakage Rate	≤5×10 <sup>-13</sup> Pa·m <sup>3</sup> /s
耐温 Temperature Resistance	-271°C~600 °C
耐气压 Pressure Tolerance	10 Bar
金属材料 Material	可伐/不锈钢 Kovar/SS

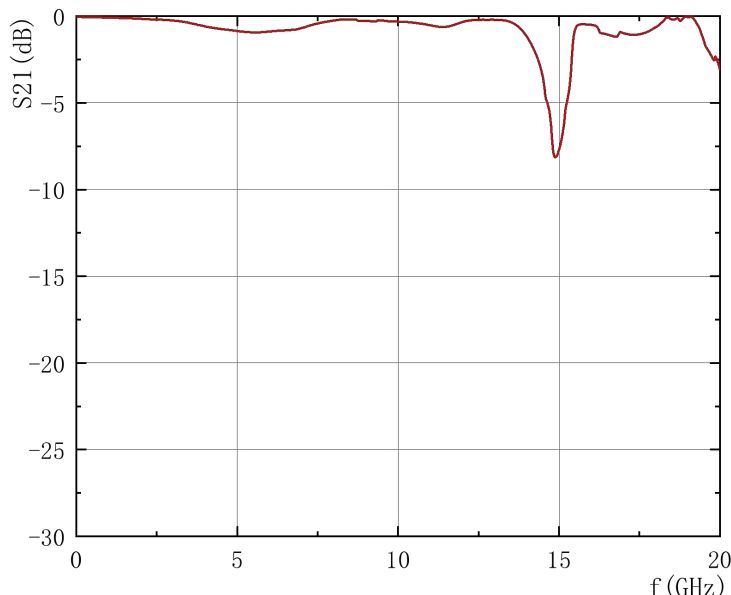

### 定制版插入损耗 Customized Insertion Loss S21 (标识代号 identification code: IL-N-C)

### ADS-FT-N-007-12.5GHz

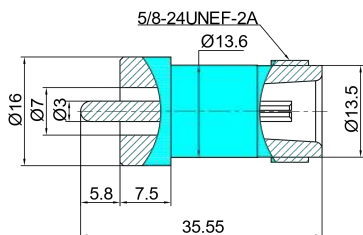

#### 技术参数 Specification

封接方式 Sealing Form	陶瓷钎焊 Ceramic Brazing
端口标准 Port Standards	N-K 光杆 Rod
最大电流 Max Current	10 A
最大电压 Max Voltage	3.5 KV
工作频率 Working Frequency	0~12.5 GHz (IL-N-C)
插损 Insertion Loss	≤1.6 dB
端口阻抗 Port Impedance	50±3 Ω
漏气率 Leakage Rate	≤5×10 <sup>-13</sup> Pa·m <sup>3</sup> /s
耐温 Temperature Resistance	-271°C~600 °C
耐气压 Pressure Tolerance	10 Bar
金属材料 Material	可伐/不锈钢 Kovar/SS

## 同轴 N 型系列 Coaxial N Series

### ADS-FT-NN-003-12.5GHz

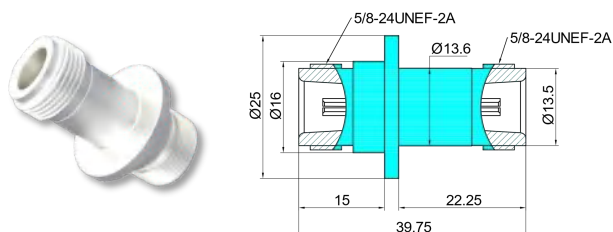

#### 技术参数 Specification

封接方式 Sealing Form	陶瓷钎焊 Ceramic Brazing
端口标准 Port Standards	N-K
最大电流 Max Current	10 A
最大电压 Max Voltage	3.5 KV
工作频率 Working Frequency	0~12.5 GHz (IL-N-C)
插损 Insertion Loss	≤1.6 dB
端口阻抗 Port Impedance	50±3 Ω
漏气率 Leakage Rate	≤5×10 <sup>-13</sup> Pa·m <sup>3</sup> /s
耐温 Temperature Resistance	-271°C~600 °C
耐气压 Pressure Tolerance	10 Bar
金属材料 Material	可伐/不锈钢 Kovar/SS

### ADS-FT-N-R-12.5GHz

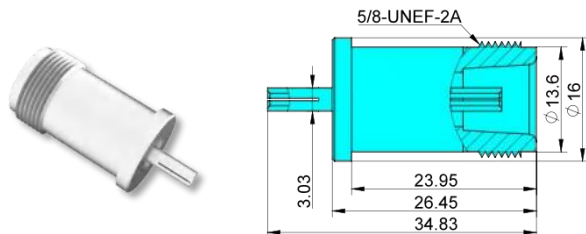

#### 技术参数 Specification

封接方式 Sealing Form	陶瓷钎焊 Ceramic Brazing
端口标准 Port Standards	N-K 插孔 Socket
最大电流 Max Current	10 A
最大电压 Max Voltage	3.5 KV
工作频率 Working Frequency	0~12.5 GHz (IL-N-C)
插损 Insertion Loss	≤1.6 dB
端口阻抗 Port Impedance	50±3 Ω
漏气率 Leakage Rate	≤5×10 <sup>-13</sup> Pa·m <sup>3</sup> /s
耐温 Temperature Resistance	-271°C~600 °C
耐气压 Pressure Tolerance	10 Bar
金属材料 Material	可伐/不锈钢 Kovar/SS

## 同轴 BNC 型系列 Coaxial BNC Series

同轴BNC型馈通用于在大气和真空间传输直流或高频信号，两端为标准BNC型射频接口，也可以根据用户需求，一端为光杆、内螺纹、外螺纹或BPM Button。根据用户需要，外导体可以为其焊接CF法兰，KF法兰，非标法兰等。

Coaxial BNC-type feedthrough is used to transmit DC or RF signals between the atmosphere and vacuum. Both ends of the feedthrough is the standard BNC-type port. Depending on user requirements, one end can be a rod, internal thread-structure, outer thread-structure, or BPM Button, while the outer conductor can be welded with the CF flange, KF flange, non-standard flange, according to user's need.

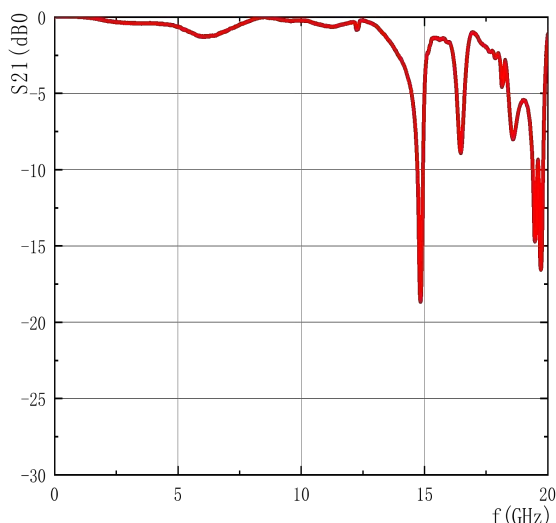

插入损耗 Insertion Loss S21  
(标识代号 identification code: IL-BNC-A)

### ADS-FT-BNC-001

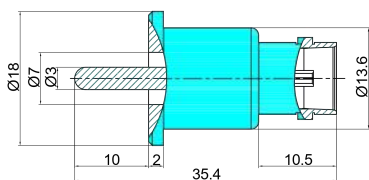

#### 技术参数 Specification

封接方式 Sealing Form	陶瓷钎焊 Ceramic Brazing
端口标准 Port Standards	BNC-K 光杆 Rod
最大电流 Max Current	7 A
最大电压 Max Voltage	4 KV
工作频率 Working Frequency	0~12 GHz (IL-BNC-A)
插损 Insertion Loss	≤1.5 dB
端口阻抗 Port Impedance	50 ± 3 Ω
漏气率 Leakage Rate	≤5 × 10 <sup>-13</sup> Pa·m <sup>3</sup> /s
耐温 Temperature Resistance	-271°C~600 °C
耐气压 Pressure Tolerance	10 Bar
金属材料 Material	可伐/不锈钢 Kovar/SS

## 同轴 BNC 型系列 Coaxial BNC Series

### ADS-FT-DBNC-001

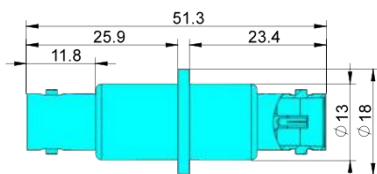

#### 技术参数 Specification

封接方式 Sealing Form	陶瓷钎焊 Ceramic Brazing
端口标准 Port Standards	BNC-K BNC-K
最大电流 Max Current	7 A
最大电压 Max Voltage	4 KV
工作频率 Working Frequency	0~12 GHz (IL-BNC-A)
插损 Insertion Loss	≤1.5 dB
端口阻抗 Port Impedance	50±3 Ω
漏气率 Leakage Rate	≤5×10 <sup>-13</sup> Pa·m <sup>3</sup> /s
耐温 Temperature Resistance	-271°C~600 °C
耐气压 Pressure Tolerance	10 Bar
金属材料 Material	可伐/不锈钢 Kovar/SS

## 同轴 L29 型系列 Coaxial L29 Series

同轴L29(7/16)型馈通用于在大气和真空间传输直流或高频信号，两端为标准L29(7/16)型射频接口，也可以根据用户需求，一端为光杆、内螺纹、外螺纹或BPM Button。根据用户需要，外导体可以为其焊接CF法兰，KF法兰，非标法兰等。

Coaxial L29(7/16)-type feedthrough is used to transmit DC or RF signals between the atmosphere and vacuum. Both ends of the feedthrough is the standard L29(7/16)-type port. Depending on user requirements, one end can be a rod, internal thread-structure, outer thread-structure, or BPM Button, while the outer conductor can be welded with the CF flange, KF flange, non-standard flange, according to user's need.

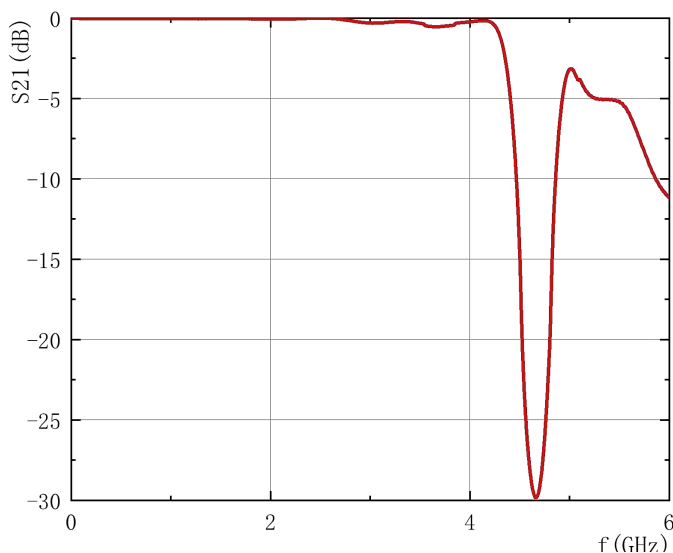

插入损耗 Insertion Loss S21  
(标识代号 identification code: IL-L29-A)

### ADS-FT-L29-001

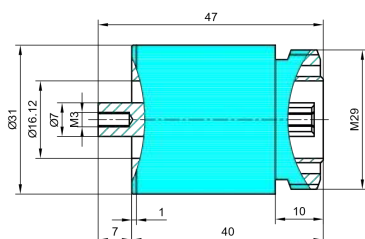

#### 技术参数 Specification

封接方式 Sealing Form	陶瓷钎焊 Ceramic Brazing
端口标准 Port Standards	L29 (7/16)-K 内螺纹 Internal thread
最大电流 Max Current	23 A
最大电压 Max Voltage	6.5 KV
工作频率 Working Frequency	0~4.2 GHz (IL-L29-A)
插损 Insertion Loss	≤0.6 dB
端口阻抗 Port Impedance	50 ± 3 Ω
漏气率 Leakage Rate	≤5 × 10 <sup>-13</sup> Pa·m <sup>3</sup> /s
耐温 Temperature Resistance	-271°C~600 °C
耐气压 Pressure Tolerance	10 Bar
金属材料 Material	可伐/不锈钢 Kovar/SS

## 同轴 L29 型系列 Coaxial L29 Series

### ADS-FT-DL29-001

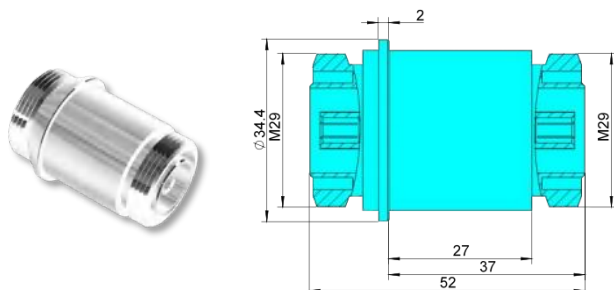

#### 技术参数 Specification

封接方式 Sealing Form	陶瓷钎焊 Ceramic Brazing
端口标准 Port Standards	L29 (7/16)-K
最大电流 Max Current	23 A
最大电压 Max Voltage	6.5 KV
工作频率 Working Frequency	0~4.2 GHz (IL-L29-A)
插损 Insertion Loss	≤0.6 dB
端口阻抗 Port Impedance	50±3 Ω
漏气率 Leakage Rate	≤5×10 <sup>-13</sup> Pa·m <sup>3</sup> /s
耐温 Temperature Resistance	-271°C~600 °C
耐气压 Pressure Tolerance	10 Bar
金属材料 Material	可伐/不锈钢 Kovar/SS

### ADS-FT-DL29-CF63-FG

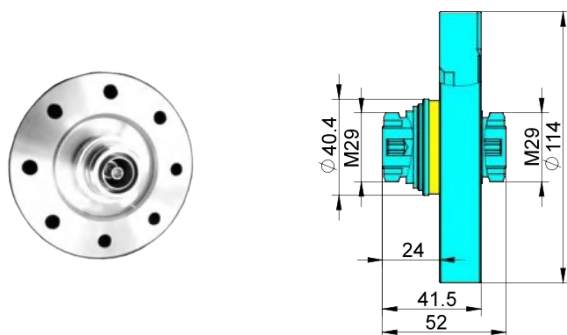

#### 技术参数 Specification

封接方式 Sealing Form	陶瓷钎焊 Ceramic Brazing
端口标准 Port Standards	L29 (7/16)-K
最大电流 Max Current	23 A
最大电压 Max Voltage	6.5 KV
工作频率 Working Frequency	0~4.2 GHz (IL-L29-A)
插损 Insertion Loss	≤0.6 dB
端口阻抗 Port Impedance	50±3 Ω
漏气率 Leakage Rate	≤5×10 <sup>-13</sup> Pa·m <sup>3</sup> /s
耐温 Temperature Resistance	-271°C~600 °C
耐气压 Pressure Tolerance	10 Bar
金属材料 Material	可伐/不锈钢 Kovar/SS

## 同轴 BPM 纽扣系列 Coaxial BPM Buttons Series

BPM 纽扣是专门为带电粒子加速器束流位置探测器（Beam Position Monitor）探头开发的纽扣（Button）型馈通。其大气端接口为标准SMA或N型接口。

BPM Button is a special feedthrough used on the Beam Position Monitor's (BPM) production. The air-side end of the feedthrough is a standard SMA- or N-type port, another end is a button according to the customer's requirements.

注：纽扣型Feedthrough标示的插损性能为标准端口到陶瓷段部分

Note: The insertion loss performance indicated by the button type Feedthrough is from the standard port to the ceramic section

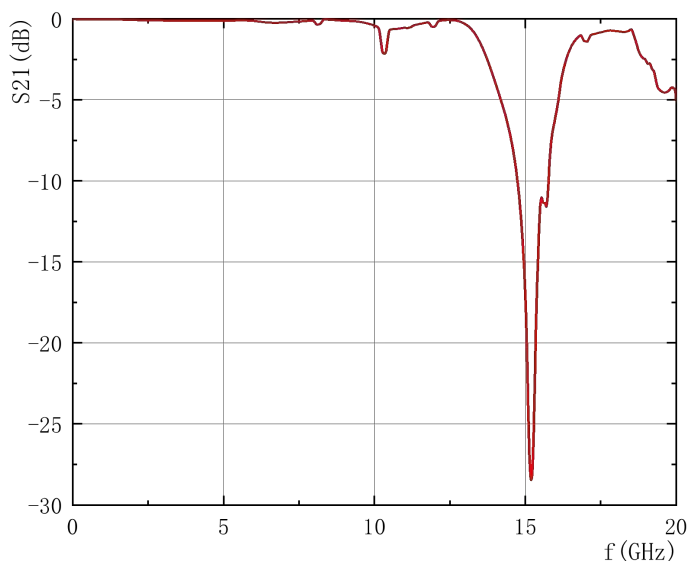

插入损耗 Insertion Loss S21  
(标识代号 identification code: IL-BT-N-A)

### ADS-FT-N-BT-001

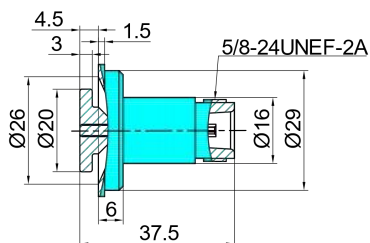

技术参数 Specification	
封接方式 Sealing Form	陶瓷钎焊 Ceramic Brazing
端口标准 Port Standards	N-K 纽扣 Button
最大电流 Max Current	10.0 A
最大电压 Max Voltage	3.0 KV
工作频率 Working Frequency	0~10 GHz (IL-BT-N-A)
插损 Insertion Loss	≤0.6 dB
端口阻抗 Port Impedance	50 ± 3 Ω
漏气率 Leakage Rate	≤5 × 10 <sup>-13</sup> Pa·m <sup>3</sup> /s
耐温 Temperature Resistance	-271°C~600 °C
耐气压 Pressure Tolerance	10 Bar
金属材料 Material	可伐/不锈钢 Kovar/SS

## 同轴 BPM 纽扣系列 Coaxial BPM Buttons Series

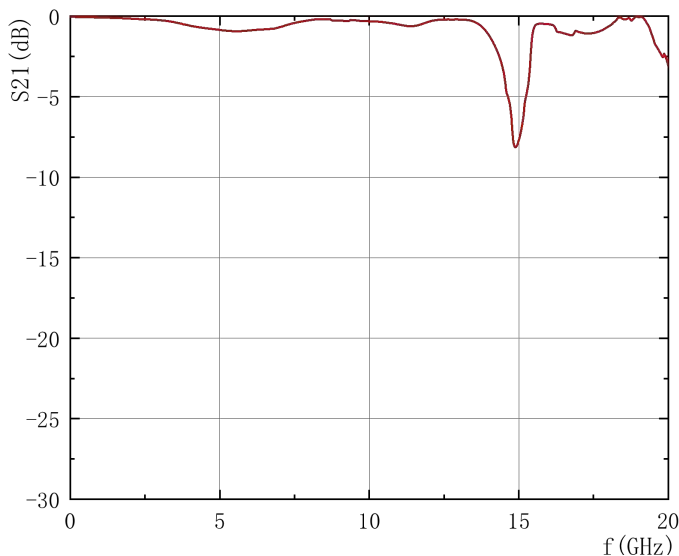

插入损耗 Insertion Loss S21  
(标识代号 identification code: IL-BT-N-B)

### ADS-FT-N-BT-002

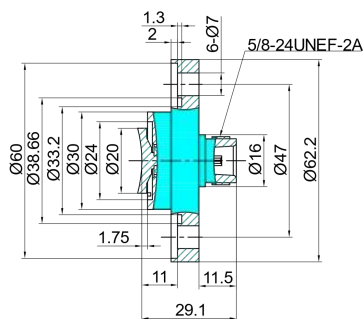

#### 技术参数 Specification

封接方式 Sealing Form	陶瓷钎焊 Ceramic Brazing
端口标准 Port Standards	N-K 纽扣 Button
最大电流 Max Current	10.0 A
最大电压 Max Voltage	3.0 KV
工作频率 Working Frequency	0~13 GHz (IL-BT-N-B)
插损 Insertion Loss	≤3.0 dB
端口阻抗 Port Impedance	50 ± 3 Ω
漏气率 Leakage Rate	≤5 × 10 <sup>-13</sup> Pa·m <sup>3</sup> /s
耐温 Temperature Resistance	-271°C~200 °C
耐气压 Pressure Tolerance	10 Bar
金属材料 Material	可伐/无氧铜/不锈钢 Kovar/OFHC/SS

### ADS-FT-N-BT-003

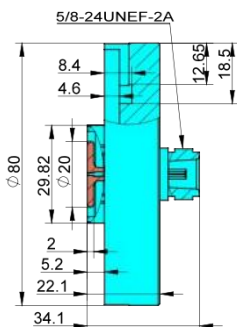

#### 技术参数 Specification

封接方式 Sealing Form	陶瓷钎焊 Ceramic Brazing
端口标准 Port Standards	N-K 纽扣 Button
最大电流 Max Current	2.0 A
最大电压 Max Voltage	3.0 KV
工作频率 Working Frequency	0~9 GHz
插损 Insertion Loss	≤2.0 dB
端口阻抗 Port Impedance	50 ± 3 Ω
漏气率 Leakage Rate	≤5 × 10 <sup>-13</sup> Pa·m <sup>3</sup> /s
耐温 Temperature Resistance	-271°C~200 °C
耐气压 Pressure Tolerance	10 Bar
金属材料 Material	钛/无氧铜 Titanium/OFHC

## 同轴 BPM 纽扣系列 Coaxial BPM Buttons Series

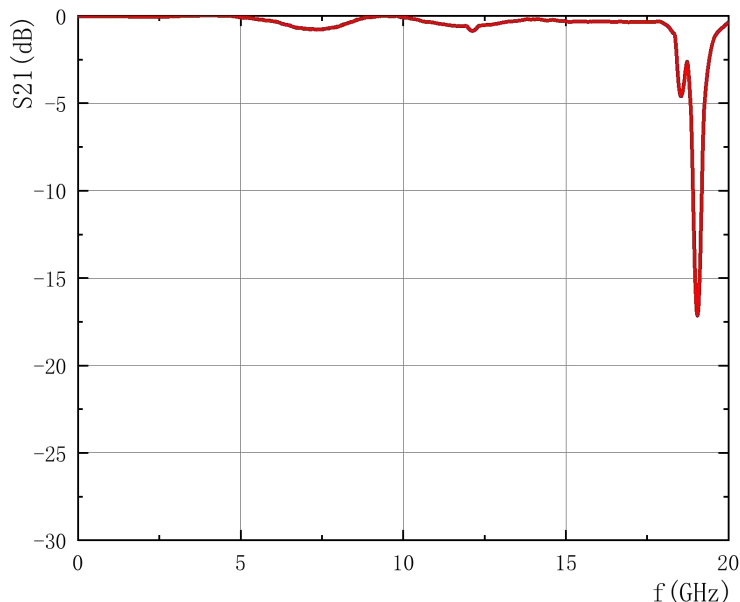

插入损耗 Insertion Loss S21  
(标识代号 identification code: IL-BT-SMA-A)

### ADS-FT-SMA-BT-001

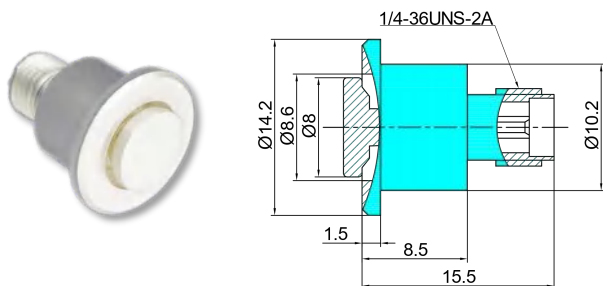

#### 技术参数 Specification

封接方式 Sealing Form	陶瓷钎焊 Ceramic Brazing
端口标准 Port Standards	SMA-K 纽扣 Button
最大电流 Max Current	5.0 A
最大电压 Max Voltage	2.5 KV
工作频率 Working Frequency	0~17 GHz (IL-BT-SMA-A)
插损 Insertion Loss	≤3.0 dB
端口阻抗 Port Impedance	50 ± 3 Ω
漏气率 Leakage Rate	≤5 × 10 <sup>-13</sup> Pa·m <sup>3</sup> /s
耐温 Temperature Resistance	-271°C~600 °C
耐气压 Pressure Tolerance	10 Bar
金属材料 Material	可伐/不锈钢 Kovar/SS

### ADS-FT-SMA-BT-002

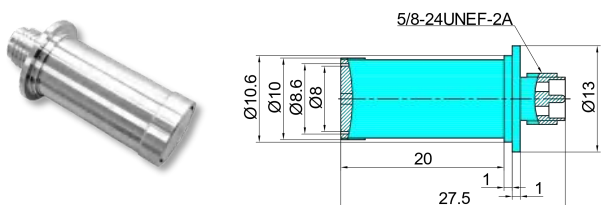

#### 技术参数 Specification

封接方式 Sealing Form	陶瓷钎焊 Ceramic Brazing
端口标准 Port Standards	SMA-RP-J 纽扣 Button
最大电流 Max Current	5.0 A
最大电压 Max Voltage	1.0 KV
工作频率 Working Frequency	0~17 GHz (IL-BT-SMA-A)
插损 Insertion Loss	≤3.0 dB
端口阻抗 Port Impedance	50 ± 3 Ω
漏气率 Leakage Rate	≤5 × 10 <sup>-13</sup> Pa·m <sup>3</sup> /s
耐温 Temperature Resistance	-271°C~600 °C
耐气压 Pressure Tolerance	10 Bar
金属材料 Material	可伐/不锈钢 Kovar/SS

## 同轴 BPM 纽扣系列 Coaxial BPM Buttons Series

### ADS-FT-SMA-BT-003

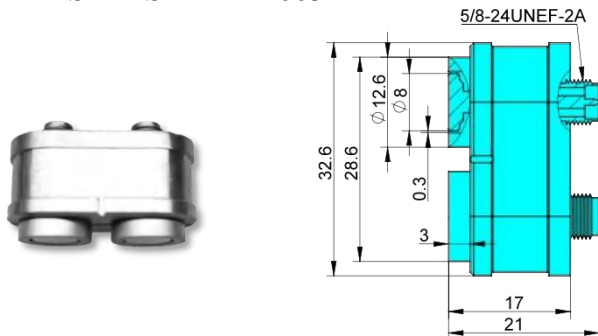

#### 技术参数 Specification

封接方式 Sealing Form	陶瓷钎焊 Ceramic Brazing
端口标准 Port Standards	SMA-RP-J 纽扣 Button
最大电流 Max Current	5.0 A
最大电压 Max Voltage	1.0 KV
工作频率 Working Frequency	0~17 GHz (IL-BT-SMA-A)
插损 Insertion Loss	≤3.0 dB
端口阻抗 Port Impedance	50±3 Ω
漏气率 Leakage Rate	≤5×10 <sup>-13</sup> Pa·m <sup>3</sup> /s
耐温 Temperature Resistance	-271°C~600 °C
耐气压 Pressure Tolerance	10 Bar
金属材料 Material	可伐/不锈钢 Kovar/SS

### ADS-FT-SMA-BT-004

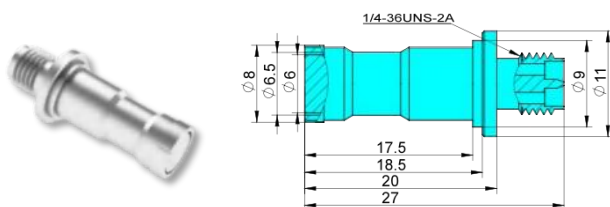

#### 技术参数 Specification

封接方式 Sealing Form	陶瓷钎焊 Ceramic Brazing
端口标准 Port Standards	SMA-RP-J 纽扣 Button
最大电流 Max Current	1.0 A
最大电压 Max Voltage	1.0 KV
工作频率 Working Frequency	0~8 GHz
插损 Insertion Loss	≤3.5 dB
端口阻抗 Port Impedance	50±3 Ω
漏气率 Leakage Rate	≤5×10 <sup>-13</sup> Pa·m <sup>3</sup> /s
耐温 Temperature Resistance	-271°C~600 °C
耐气压 Pressure Tolerance	10 Bar
金属材料 Material	钛/不锈钢 Titanium/SS

### ADS-FT-SMA-BT-005

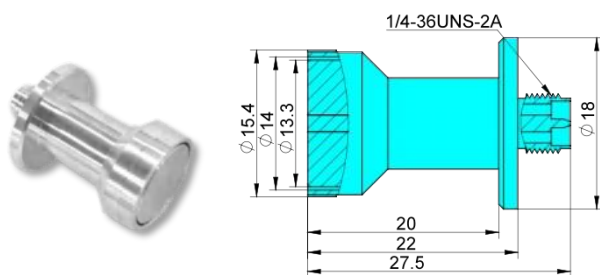

#### 技术参数 Specification

封接方式 Sealing Form	陶瓷钎焊 Ceramic Brazing
端口标准 Port Standards	SMA-RP-J 纽扣 Button
最大电流 Max Current	1.0 A
最大电压 Max Voltage	1.0 KV
工作频率 Working Frequency	0~17 GHz
插损 Insertion Loss	≤3.5 dB
端口阻抗 Port Impedance	50±3 Ω
漏气率 Leakage Rate	≤5×10 <sup>-13</sup> Pa·m <sup>3</sup> /s
耐温 Temperature Resistance	-271°C~600 °C
耐气压 Pressure Tolerance	10 Bar
金属材料 Material	钛/不锈钢 Titanium/SS

## 三同轴 TRB型系列 Triple Coaxial TRB Series

三同轴TRB型馈通用于在大气和真空间传输直流或高频信号，两端为标准TRB型射频接口，也可以根据用户需求，一端为光杆、内螺纹、外螺纹或BPM Button。根据用户需要，外导体可以为其焊接CF法兰，KF法兰，非标法兰等。

Triple Coaxial TRB-type feedthrough is used to transmit DC or RF signals between the atmosphere and vacuum. Both ends of the feedthrough is the standard TRB-type port. Depending on user requirements, one end can be a rod, internal thread-structure, outer thread-structure, or BPM Button, while the outer conductor can be welded with the CF flange, KF flange, non-standard flange, according to user's need.

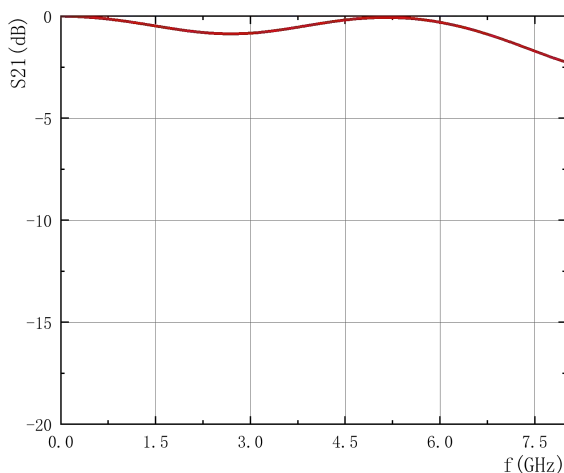

插入损耗 Insertion Loss S21  
(标识代号 identification code: IL-TRB-A)

### ADS-FT-TRB-001

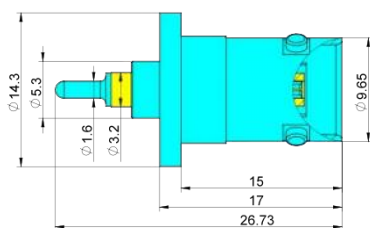

技术参数	Specification
封接方式 Sealing Form	陶瓷钎焊 Ceramic Brazing
端口标准 Port Standards	TRB 光杆 Rod
最大电流 Max Current	4 A
最大电压 Max Voltage	1 KV/内-中 inner-middle 2.5 kV /中-外 middle-outside
工作频率 Working Frequency	0~7 GHz (IL-TRB-A)
插损 Insertion Loss	$\leq 2.5$ dB
端口阻抗 Port Impedance	$\leq 5 \times 10^{-13}$ Pa·m <sup>3</sup> /s
漏气率 Leakage Rate	-271°C~600 °C
耐温 Temperature Resistance	10 Bar
耐气压 Pressure Tolerance	可伐/不锈钢 Kovar/SS
金属材料 Material	TRB 光杆 Rod

## 大功率微波窗系列

### High Power Microwave Window Series

大功率微波窗（RF Window）是用于大气与真空之间进行大功率微波传输的接插件。微波窗有同轴与矩形两种，分别对应同轴波导和矩形波导。安德信科技具有多年设计与生产大功率微波窗的经验。

High-power RF windows are used to transmit the microwave power between the atmosphere and vacuum. Here we offer the coaxial and rectangular windows, which are used to connect the coaxial and rectangular waveguides respectively. ANDESUN Technology has many years of experience in designing and producing high-power microwave windows.

#### ADS-Coaxial Windows



技术参数 Specification

封接方式 Sealing Form	陶瓷钎焊 Ceramic Brazing
端口标准 Port Standards	同轴波导 coaxial waveguide
最大功率（kW） Max Power	1000
工作频率 Working Frequency	100MHz ~2.998 GHz
插损 Insertion Loss	≤0.6 dB
端口阻抗 Port Impedance	50 ± 3 Ω
漏气率 Leakage Rate	≤5 × 10 <sup>-13</sup> Pa·m <sup>3</sup> /s
耐温 Temperature Resistance	-20°C~200 °C
耐气压 Pressure Tolerance	10 Bar
金属材料 Material	可伐/不锈钢/无氧铜 Kovar/SS/OFHC

## 多针系列 Multi-pin Series

多针馈通用于在大气和真空间传输多路直流或低频信号，通常一端为通用标准接口，另一端为焊杯、光杆或标准接口。安装密封方式，根据用户需求，可以为焊接，CF法兰，KF法兰，非标法兰等。

Multipin feedthrough is used to transmit multi-way DC or low-frequency signals in the atmosphere and vacuum. Usually, one end is a standard connector, and another end is a soldering cup, rod, or a standard connector. The installation sealing method can be welding, CF flange, KF flange, non-standard flange, etc. according to user's need.

### ADS-FT-1PIN-1KV-WD

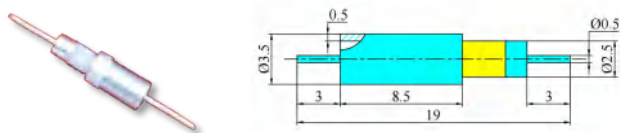

#### 技术参数 Specification

封接方式 Sealing Form	陶瓷钎焊 Ceramic Brazing
针数 Number of pins	单针 One Pin
端口标准 Port Standards	光杆 Rod
最大电流 Max Current	1.5 A
最大电压 Max Voltage	1 KV
绝缘阻抗 Insulation resistance	$\geq 1 \times 10^9 \Omega$
漏气率 Leakage Rate	$\leq 5 \times 10^{-13} \text{ Pa} \cdot \text{m}^3/\text{s}$
耐温 Temperature Resistance	-271°C~600°C
耐气压 Pressure Tolerance	10 Bar
金属材料 Material	可伐/无氧铜 Kovar/OFC

### ADS-FT-1PIN-10KV-OR

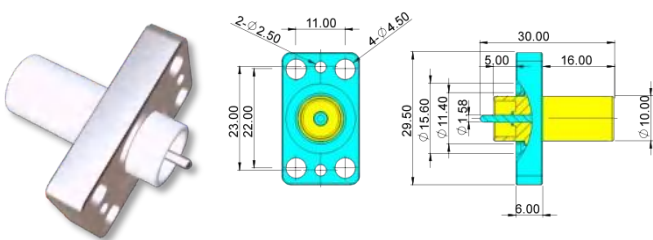

#### 技术参数 Specification

封接方式 Sealing Form	陶瓷钎焊 Ceramic Brazing
针数 Number of pins	单针 One Pin
端口标准 Port Standards	光杆 Rod
最大电流 Max Current	2 A
最大电压 Max Voltage	10 KV
绝缘阻抗 Insulation resistance	$\geq 1 \times 10^9 \Omega$
漏气率 Leakage Rate	$\leq 5 \times 10^{-13} \text{ Pa} \cdot \text{m}^3/\text{s}$
耐温 Temperature Resistance	-271°C~600 °C
耐气压 Pressure Tolerance	10 Bar
金属材料 Material	可伐/不锈钢 Kovar/SS

### ADS-FT-2PIN-10KV-CF16

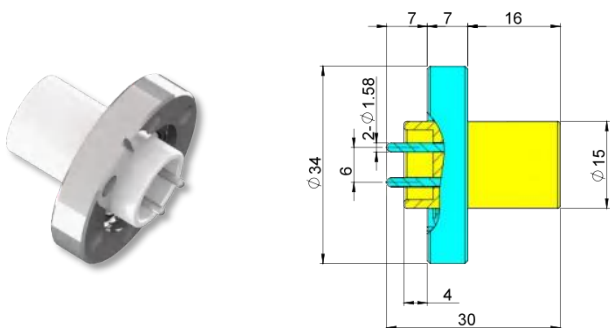

#### 技术参数 Specification

封接方式 Sealing Form	陶瓷钎焊 Ceramic Brazing
针数 Number of pins	2 Pins
端口标准 Port Standards	光杆 Rod
最大电流 Max Current	3 A
最大电压 Max Voltage	10 KV
绝缘阻抗 Insulation resistance	$\geq 1 \times 10^9 \Omega$
漏气率 Leakage Rate	$\leq 5 \times 10^{-13} \text{ Pa} \cdot \text{m}^3/\text{s}$
耐温 Temperature Resistance	-271°C~600 °C
耐气压 Pressure Tolerance	10 Bar
金属材料 Material	可伐/不锈钢 Kovar/SS

## 多针系列 Multi-pin Series

### ADS-FT-4PIN-8KV-CF16

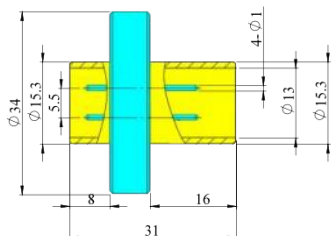

#### 技术参数 Specification

封接方式 Sealing Form	陶瓷钎焊 Ceramic Brazing
针数 Number of pins	4 Pins
端口标准 Port Standards	光杆 Rod
最大电流 Max Current	1.3 A
最大电压 Max Voltage	8 KV
绝缘阻抗 Insulation resistance	$\geq 1 \times 10^9 \Omega$
漏气率 Leakage Rate	$\leq 5 \times 10^{-13} \text{ Pa} \cdot \text{m}^3/\text{s}$
耐温 Temperature Resistance	-271°C~600 °C
耐气压 Pressure Tolerance	10 Bar
金属材料 Material	可伐/不锈钢 Kovar/SS

### ADS-FT-8PIN-1KV-CF16

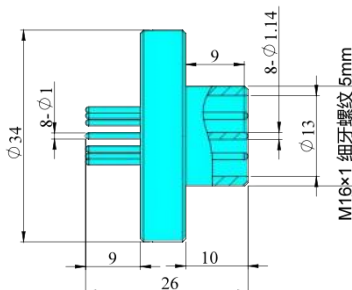

#### 技术参数 Specification

封接方式 Sealing Form	陶瓷钎焊 Ceramic Brazing
针数 Number of pins	8 Pins
端口标准 Port Standards	光杆 Rod
最大电流 Max Current	1.5A
最大电压 Max Voltage	1 KV
绝缘阻抗 Insulation resistance	$\geq 1 \times 10^9 \Omega$
漏气率 Leakage Rate	$\leq 5 \times 10^{-13} \text{ Pa} \cdot \text{m}^3/\text{s}$
耐温 Temperature Resistance	-271°C~600 °C
耐气压 Pressure Tolerance	10 Bar
金属材料 Material	可伐/不锈钢 Kovar/SS

### ADS-FT-JC-4PIN-8KV-WD

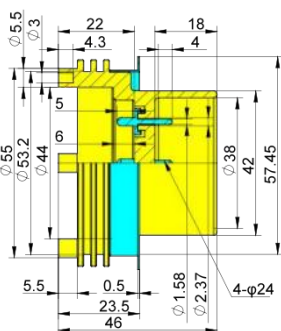
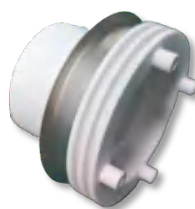

#### 技术参数 Specification

封接方式 Sealing Form	陶瓷钎焊 Ceramic Brazing
针数 Number of pins	4 Pins
端口标准 Port Standards	光杆 Rod
最大电流 Max Current	4 A
最大电压 Max Voltage	8 KV
绝缘阻抗 Insulation resistance	$\geq 1 \times 10^9 \Omega$
漏气率 Leakage Rate	$\leq 5 \times 10^{-13} \text{ Pa} \cdot \text{m}^3/\text{s}$
耐温 Temperature Resistance	-271°C~600 °C
耐气压 Pressure Tolerance	10 Bar
金属材料 Material	可伐/不锈钢 Kovar/SS

### ADS-FT-FM-3KV-30A-4PIN-WD

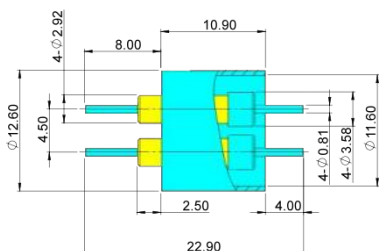

#### 技术参数 Specification

封接方式 Sealing Form	陶瓷钎焊 Ceramic Brazing
针数 Number of pins	4 Pins
端口标准 Port Standards	光杆 Rod
最大电流 Max Current	30A
最大电压 Max Voltage	3 KV
绝缘阻抗 Insulation resistance	$\geq 1 \times 10^9 \Omega$
漏气率 Leakage Rate	$\leq 5 \times 10^{-13} \text{ Pa} \cdot \text{m}^3/\text{s}$
耐温 Temperature Resistance	-271°C~600 °C
耐气压 Pressure Tolerance	10 Bar
金属材料 Material	可伐/无氧铜 Kovar/OFHC

## 多针系列 Multi-pin Series — 焊线式 Solderable

焊线式多针馈通的内导体两端为焊杯结构，可以方便的焊接导线，适用于结构紧凑的场景。安装密封方式，根据用户需求，可以为焊接，CF法兰，KF法兰，非标法兰等。

Both ends of the inner conductor of the solderable multi-pin feedthrough have a soldering cup structure, which can conveniently weld wires and is suitable for scenarios with compact structure. The installation sealing method can be welding, CF flange, KF flange, non-standard flange, etc. according to user's need.

### ADS-FT-19PIN-DHB-WD

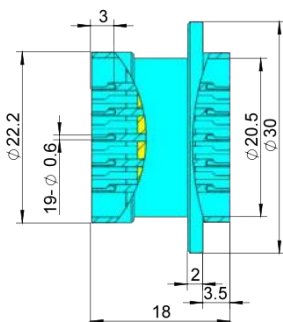

#### 技术参数 Specification

封接方式 Sealing Form	陶瓷钎焊 Ceramic Brazing
针数 Number of pins	19 Pins
端口标准 Port Standards	焊线插针 Solderable Pin
最大电流 Max Current	1.3 A
最大电压 Max Voltage	1 KV
绝缘阻抗 Insulation resistance	$\geq 1 \times 10^9 \Omega$
漏气率 Leakage Rate	$\leq 5 \times 10^{-13} \text{ Pa} \cdot \text{m}^3/\text{s}$
耐温 Temperature Resistance	-271°C~600 °C
耐气压 Pressure Tolerance	10 Bar
金属材料 Material	可伐/不锈钢 Kovar/SS

### ADS-FT-32PIN-DHB-WD

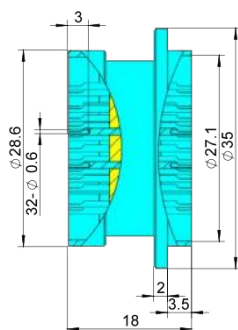

#### 技术参数 Specification

封接方式 Sealing Form	陶瓷钎焊 Ceramic Brazing
针数 Number of pins	32 Pins
端口标准 Port Standards	焊线插针 Solderable Pin
最大电流 Max Current	1.3 A
最大电压 Max Voltage	1 KV
绝缘阻抗 Insulation resistance	$\geq 1 \times 10^9 \Omega$
漏气率 Leakage Rate	$\leq 5 \times 10^{-13} \text{ Pa} \cdot \text{m}^3/\text{s}$
耐温 Temperature Resistance	-271°C~600 °C
耐气压 Pressure Tolerance	10 Bar
金属材料 Material	可伐/不锈钢 Kovar/SS

### ADS-FT-41PIN-DHB-WD

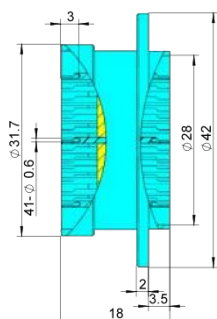

#### 技术参数 Specification

封接方式 Sealing Form	陶瓷钎焊 Ceramic Brazing
针数 Number of pins	41 Pins
端口标准 Port Standards	焊线插针 Solderable Pin
最大电流 Max Current	1.3 A
最大电压 Max Voltage	1 KV
绝缘阻抗 Insulation resistance	$\geq 1 \times 10^9 \Omega$
漏气率 Leakage Rate	$\leq 5 \times 10^{-13} \text{ Pa} \cdot \text{m}^3/\text{s}$
耐温 Temperature Resistance	-271°C~600 °C
耐气压 Pressure Tolerance	10 Bar
金属材料 Material	可伐/不锈钢 Kovar/SS

## 多针系列 Multi-pin Series — 焊线式 Solderable

ADS-FT-55PIN-DHB-WD

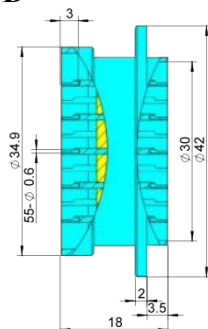
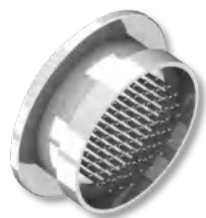

技术参数 Specification

封接方式 Sealing Form	陶瓷钎焊 Ceramic Brazing
针数 Number of pins	55 Pins
端口标准 Port Standards	焊线插针 Solderable Pin
最大电流 Max Current	1.3 A
最大电压 Max Voltage	1 KV
绝缘阻抗 Insulation resistance	$\geq 1 \times 10^9 \Omega$
漏气率 Leakage Rate	$\leq 5 \times 10^{-13} \text{ Pa} \cdot \text{m}^3/\text{s}$
耐温 Temperature Resistance	-271°C~600 °C
耐气压 Pressure Tolerance	10 Bar
金属材料 Material	可伐/不锈钢 Kovar/SS

## 多针系列 Multi-pin Series — GJB 598

GJB 598系列多针馈通具有不容易断开的卡扣连接方式，具有连接快速，接触稳定的特点。GJB 598系列两端都为标准多针接口，符合GJB 598和GJB 1610规范。

GJB 598 series multi-pin Feedthrough has a snap-on connection mode that is not easy to disconnect, and has the characteristics of fast connection and stable contact. Both ends of the GJB 598 series are standard multi-pin interfaces, which meet the GJB 598 and GJB 1610 specifications.

### ADS-FT-598-M24-19PIN-WD

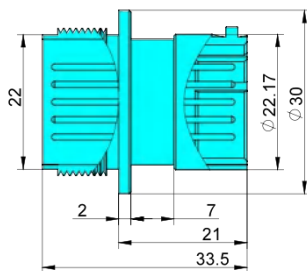

#### 技术参数 Specification

封接方式 Sealing Form	陶瓷钎焊 Ceramic Brazing
针数 Number of pins	19 Pins
端口标准 Port Standards	GJB 598B-2011 GJB 1610A-2011
最大电流 Max Current	1.3 A
最大电压 Max Voltage	1 KV
绝缘阻抗 Insulation resistance	$\geq 1 \times 10^9 \Omega$
漏气率 Leakage Rate	$\leq 5 \times 10^{-13} \text{ Pa} \cdot \text{m}^3/\text{s}$
耐温 Temperature Resistance	-271°C~600 °C
耐气压 Pressure Tolerance	10 Bar
金属材料 Material	可伐/不锈钢 Kovar/SS

### ADS-FT-598-M30-32PIN-WD

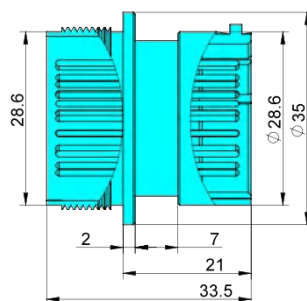

#### 技术参数 Specification

封接方式 Sealing Form	陶瓷钎焊 Ceramic Brazing
针数 Number of pins	32 Pins
端口标准 Port Standards	GJB 598B-2011 GJB 1610A-2011
最大电流 Max Current	1.3 A
最大电压 Max Voltage	1 KV
绝缘阻抗 Insulation resistance	$\geq 1 \times 10^9 \Omega$
漏气率 Leakage Rate	$\leq 5 \times 10^{-13} \text{ Pa} \cdot \text{m}^3/\text{s}$
耐温 Temperature Resistance	-271°C~600 °C
耐气压 Pressure Tolerance	10 Bar
金属材料 Material	可伐/不锈钢 Kovar/SS

### ADS-FT-598-M32-41PIN-WD

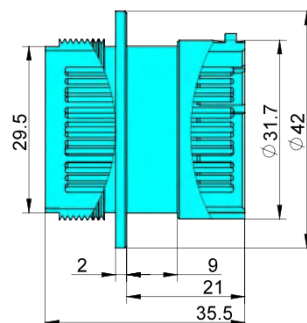

#### 技术参数 Specification

封接方式 Sealing Form	陶瓷钎焊 Ceramic Brazing
针数 Number of pins	41 Pins
端口标准 Port Standards	GJB 598B-2011 GJB 1610A-2011
最大电流 Max Current	1.3 A
最大电压 Max Voltage	1 KV
绝缘阻抗 Insulation resistance	$\geq 1 \times 10^9 \Omega$
漏气率 Leakage Rate	$\leq 5 \times 10^{-13} \text{ Pa} \cdot \text{m}^3/\text{s}$
耐温 Temperature Resistance	-271°C~600 °C
耐气压 Pressure Tolerance	10 Bar
金属材料 Material	可伐/不锈钢 Kovar/SS

## 多针系列 Multi-pin Series — GJB 598

### ADS-FT-598-M34-55PIN-WD

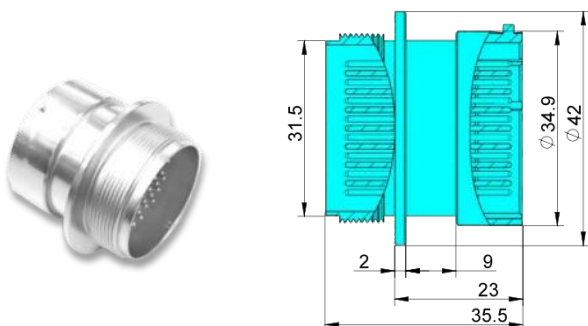

#### 技术参数 Specification

封接方式 Sealing Form	陶瓷钎焊 Ceramic Brazing
针数 Number of pins	55 Pins
端口标准 Port Standards	GJB 598B-2011 GJB 1610A-2011
最大电流 Max Current	1.3 A
最大电压 Max Voltage	1 KV
绝缘阻抗 Insulation resistance	$\geq 1 \times 10^9 \Omega$
漏气率 Leakage Rate	$\leq 5 \times 10^{-13} \text{ Pa} \cdot \text{m}^3/\text{s}$
耐温 Temperature Resistance	-271°C~600 °C
耐气压 Pressure Tolerance	10 Bar
金属材料 Material	可伐/不锈钢 Kovar/SS

### ADS-FT-598-M24-19PIN-CF35

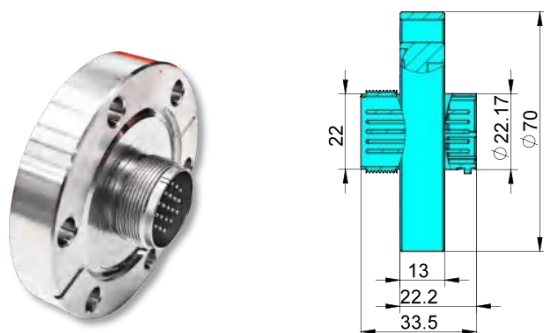

#### 技术参数 Specification

封接方式 Sealing Form	陶瓷钎焊 Ceramic Brazing
针数 Number of pins	19 Pins
端口标准 Port Standards	GJB 598B-2011 GJB 1610A-2011
最大电流 Max Current	1.3 A
最大电压 Max Voltage	1 KV
绝缘阻抗 Insulation resistance	$\geq 1 \times 10^9 \Omega$
漏气率 Leakage Rate	$\leq 5 \times 10^{-13} \text{ Pa} \cdot \text{m}^3/\text{s}$
耐温 Temperature Resistance	-271°C~600 °C
耐气压 Pressure Tolerance	10 Bar
金属材料 Material	可伐/不锈钢 Kovar/SS

### ADS-FT-598-M30-32PIN-CF35

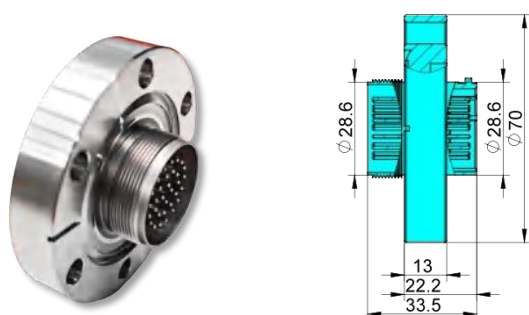

#### 技术参数 Specification

封接方式 Sealing Form	陶瓷钎焊 Ceramic Brazing
针数 Number of pins	32 Pins
端口标准 Port Standards	GJB 598B-2011 GJB 1610A-2011
最大电流 Max Current	1.3 A
最大电压 Max Voltage	1 KV
绝缘阻抗 Insulation resistance	$\geq 1 \times 10^9 \Omega$
漏气率 Leakage Rate	$\leq 5 \times 10^{-13} \text{ Pa} \cdot \text{m}^3/\text{s}$
耐温 Temperature Resistance	-271°C~600 °C
耐气压 Pressure Tolerance	10 Bar
金属材料 Material	可伐/不锈钢 Kovar/SS

### ADS-FT-598-M32-41PIN-CF50

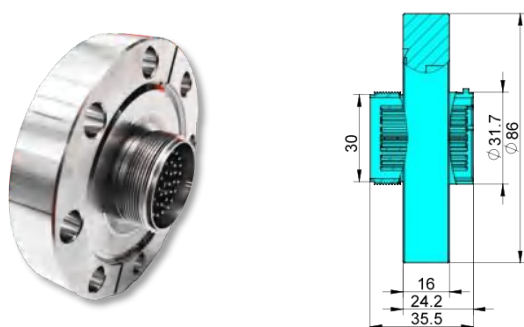

#### 技术参数 Specification

封接方式 Sealing Form	陶瓷钎焊 Ceramic Brazing
针数 Number of pins	41 Pins
端口标准 Port Standards	GJB 598B-2011 GJB 1610A-2011
最大电流 Max Current	1.3 A
最大电压 Max Voltage	1 KV
绝缘阻抗 Insulation resistance	$\geq 1 \times 10^9 \Omega$
漏气率 Leakage Rate	$\leq 5 \times 10^{-13} \text{ Pa} \cdot \text{m}^3/\text{s}$
耐温 Temperature Resistance	-271°C~600 °C
耐气压 Pressure Tolerance	10 Bar
金属材料 Material	可伐/不锈钢 Kovar/SS

## 多针系列 Multi-pin Series — GJB 598

### ADS-FT-598-M34-55PIN-CF50

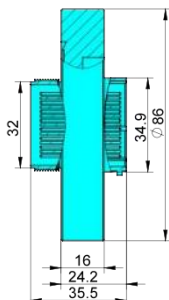

#### 技术参数 Specification

封接方式 Sealing Form	陶瓷钎焊 Ceramic Brazing
针数 Number of pins	55 Pins
端口标准 Port Standards	GJB 598B-2011 GJB 1610A-2011
最大电流 Max Current	1.3 A
最大电压 Max Voltage	1 KV
绝缘阻抗 Insulation resistance	$\geq 1 \times 10^9 \Omega$
漏气率 Leakage Rate	$\leq 5 \times 10^{-13} \text{ Pa}\cdot\text{m}^3/\text{s}$
耐温 Temperature Resistance	-271°C~600 °C
耐气压 Pressure Tolerance	10 Bar
金属材料 Material	可伐/不锈钢 Kovar/SS

### ADS-FT-1610-19PIN-VC-CRE (真空侧陶瓷接头, Vacuum side ceramic connectors)

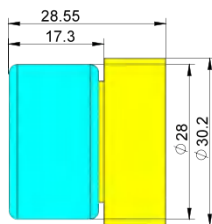
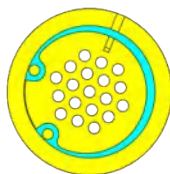

#### 技术参数 Specification

绝缘材料 Insulating Material	陶瓷 Ceramic
针数 Number of pins	19 Pins
端口标准 Port Standards	压接针 Crimping Pin GJB 1610A-2011
最大电流 Max Current	1.3 A
最大电压 Max Voltage	1 KV
绝缘阻抗 Insulation resistance	$\geq 1 \times 10^9 \Omega$
耐温 Temperature Resistance	-271°C~600 °C
金属材料 Material	不锈钢 SS

### ADS-FT-1610-32PIN-VC-CRE (真空侧陶瓷接头, Vacuum side ceramic connectors)

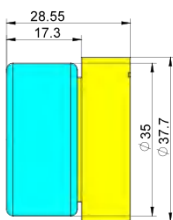
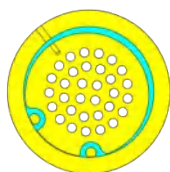

#### 技术参数 Specification

绝缘材料 Insulating Material	陶瓷 Ceramic
针数 Number of pins	32 Pins
端口标准 Port Standards	压接针 Crimping Pin GJB 1610A-2011
最大电流 Max Current	1.3 A
最大电压 Max Voltage	1 KV
绝缘阻抗 Insulation resistance	$\geq 1 \times 10^9 \Omega$
耐温 Temperature Resistance	-271°C~600 °C
金属材料 Material	不锈钢 SS

### ADS-FT-1610-41PIN-VC-CRE (真空侧陶瓷接头, Vacuum side ceramic connectors)

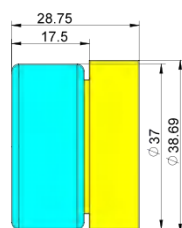
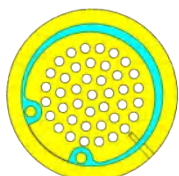

#### 技术参数 Specification

绝缘材料 Insulating Material	陶瓷 Ceramic
针数 Number of pins	41 Pins
端口标准 Port Standards	压接针 Crimping Pin GJB 1610A-2011
最大电流 Max Current	1.3 A
最大电压 Max Voltage	1 KV
绝缘阻抗 Insulation resistance	$\geq 1 \times 10^9 \Omega$
耐温 Temperature Resistance	-271°C~600 °C
金属材料 Material	不锈钢 SS



## 多针系列 Multi-pin Series — GJB 598

### ADS-FT-598-55PIN-AIR-CRE (大气侧陶瓷接头, Atmospheric side ceramic connectors)

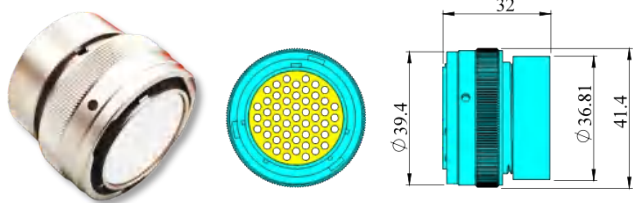

技术参数 Specification

绝缘材料 Insulating Material	陶瓷 Ceramic
针数 Number of pins	55 Pins
端口标准 Port Standards	压接针 Crimping Pin GJB 598B-2011
最大电流 Max Current	1.3 A
最大电压 Max Voltage	1 KV
绝缘阻抗 Insulation resistance	$\geq 1 \times 10^9 \Omega$
耐温 Temperature Resistance	-271°C~400 °C
金属材料 Material	铝/不锈钢 Aluminium/SS

### ADS-FT-598-19PIN-VC-PEEK (真空侧PEEK接头, Vacuum side PEEK connector)

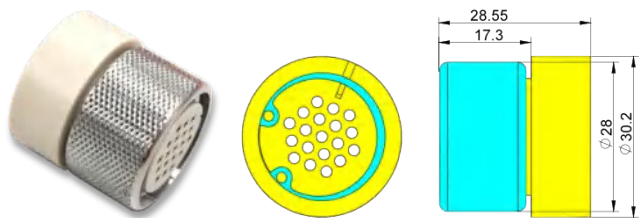

技术参数 Specification

绝缘材料 Insulating Material	PEEK
针数 Number of pins	19 Pins
端口标准 Port Standards	压接针 Crimping Pin GJB 1610A-2011
最大电流 Max Current	1.3 A
最大电压 Max Voltage	1 KV
绝缘阻抗 Insulation resistance	$\geq 1 \times 10^9 \Omega$
耐温 Temperature Resistance	-271°C~250 °C
金属材料 Material	不锈钢 SS

### ADS-FT-598-32PIN-VC-PEEK (真空侧PEEK接头, Vacuum side PEEK connector)

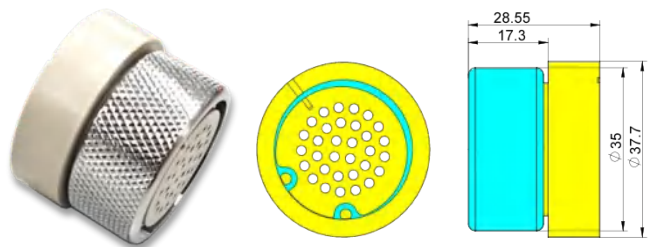

技术参数 Specification

绝缘材料 Insulating Material	PEEK
针数 Number of pins	32 Pins
端口标准 Port Standards	压接针 Crimping Pin GJB 1610A-2011
最大电流 Max Current	1.3 A
最大电压 Max Voltage	1 KV
绝缘阻抗 Insulation resistance	$\geq 1 \times 10^9 \Omega$
耐温 Temperature Resistance	-271°C~250 °C
金属材料 Material	不锈钢 SS

### ADS-FT-598-41PIN-VC-PEEK (真空侧PEEK接头, Vacuum side PEEK connector)

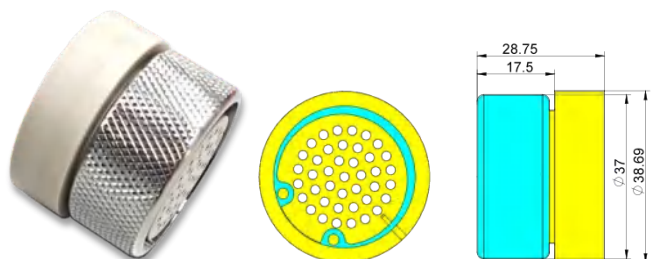

技术参数 Specification

绝缘材料 Insulating Material	PEEK
针数 Number of pins	41 Pins
端口标准 Port Standards	压接针 Crimping Pin GJB 1610A-2011
最大电流 Max Current	1.3 A
最大电压 Max Voltage	1 KV
绝缘阻抗 Insulation resistance	$\geq 1 \times 10^9 \Omega$
耐温 Temperature Resistance	-271°C~250 °C
金属材料 Material	不锈钢 SS

## 多针系列 Multi-pin Series — GJB 598

### ADS-FT-598-55PIN-VC-PEEK (真空侧PEEK接头, Vacuum side PEEK connector)

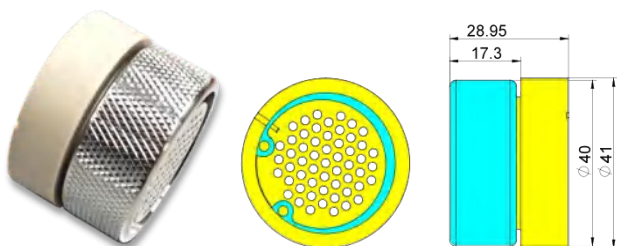

技术参数 Specification

绝缘材料 Insulating Material	PEEK
针数 Number of pins	55 Pins
端口标准 Port Standards	压接针 Crimping Pin GJB 1610A-2011
最大电流 Max Current	1.3 A
最大电压 Max Voltage	1 KV
绝缘阻抗 Insulation resistance	$\geq 1 \times 10^9 \Omega$
耐温 Temperature Resistance	-271°C~250 °C
金属材料 Material	不锈钢 SS

### ADS-FT-598-19PIN-AIR-COM (大气侧普通接头, Atmospheric side common connectors)

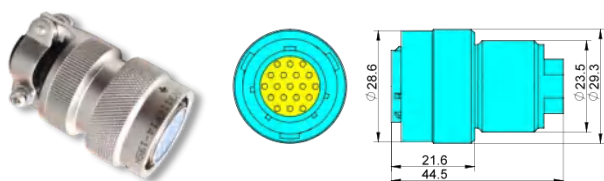

技术参数 Specification

绝缘材料 Insulating Material	塑料 Plastic
针数 Number of pins	19 Pins
端口标准 Port Standards	压接针 Crimping Pin GJB 598B-2011
最大电流 Max Current	1.3 A
最大电压 Max Voltage	1 KV
绝缘阻抗 Insulation resistance	$\geq 1 \times 10^9 \Omega$
耐温 Temperature Resistance	-60°C~120 °C
金属材料 Material	铝/不锈钢 Aluminium/SS

### ADS-FT-598-32PIN-AIR-COM (大气侧普通接头, Atmospheric side common connectors)

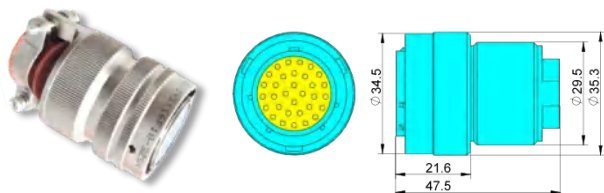

技术参数 Specification

绝缘材料 Insulating Material	塑料 Plastic
针数 Number of pins	32 Pins
端口标准 Port Standards	压接针 Crimping Pin GJB 598B-2011
最大电流 Max Current	1.3 A
最大电压 Max Voltage	1 KV
绝缘阻抗 Insulation resistance	$\geq 1 \times 10^9 \Omega$
耐温 Temperature Resistance	-60°C~120 °C
金属材料 Material	铝/不锈钢 Aluminium/SS

### ADS-FT-598-41PIN-AIR-COM (大气侧普通接头, Atmospheric side common connectors)

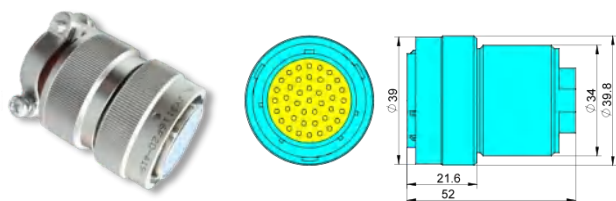

技术参数 Specification

绝缘材料 Insulating Material	塑料 Plastic
针数 Number of pins	41 Pins
端口标准 Port Standards	压接针 Crimping Pin GJB 598B-2011
最大电流 Max Current	1.3 A
最大电压 Max Voltage	1 KV
绝缘阻抗 Insulation resistance	$\geq 1 \times 10^9 \Omega$
耐温 Temperature Resistance	-60°C~120 °C
金属材料 Material	铝/不锈钢 Aluminium/SS

## 多针系列 Multi-pin Series — GJB 598

ADS-FT-598-55PIN-AIR-COM (大气侧普通接头，Atmospheric side common connectors)

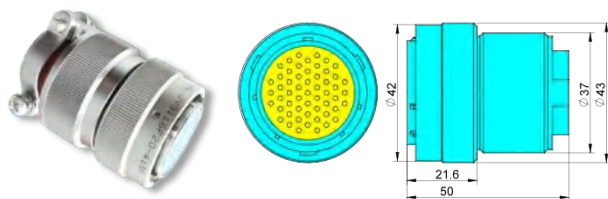

技术参数 Specification

绝缘材料 Insulating Material	塑料 Plastic
针数 Number of pins	55 Pins
端口标准 Port Standards	压接针 Crimping Pin GJB 598B-2011
最大电流 Max Current	1.3 A
最大电压 Max Voltage	1 KV
绝缘阻抗 Insulation resistance	$\geq 1 \times 10^9 \Omega$
耐温 Temperature Resistance	-60°C~120 °C
金属材料 Material	铝/不锈钢 Aluminium/SS

## 多针系列 Multi-pin Series — IEC 61076

IEC 61076系列多针馈通采用螺纹连接，提供可靠的机械锁定。端口形式一端为标准多针接口，另一端为焊杯。安装密封方式，根据用户需求，可以为焊接，CF法兰，KF法兰，非标法兰等。

The IEC 61076 Series multi-pin feedthroughs feature threaded connections that provide reliable mechanical locking. The port type features a standard multi-pin interface on one end and a solder cup on the other. The installation sealing method can be welding, CF flange, KF flange, non-standard flange, etc. according to user's need.

### ADS-FT-61076-M12-8PIN-WD

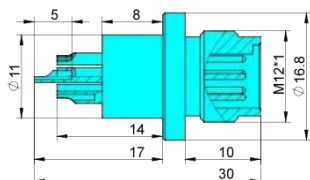

#### 技术参数 Specification

封接方式 Sealing Form	陶瓷钎焊 Ceramic Brazing
针数 Number of pins	8 Pins
端口标准 Port Standards	IEC 61076-2-101 焊接针 Solderable Pin
最大电流 Max Current	1 A
最大电压 Max Voltage	1 KV
绝缘阻抗 Insulation resistance	$\geq 1 \times 10^9 \Omega$
漏气率 Leakage Rate	$\leq 5 \times 10^{-13} \text{ Pa} \cdot \text{m}^3/\text{s}$
耐温 Temperature Resistance	-271°C~600 °C
耐气压 Pressure Tolerance	10 Bar
金属材料 Material	可伐/不锈钢 Kovar/SS

### ADS-FT-61076-M12-8PIN-OR

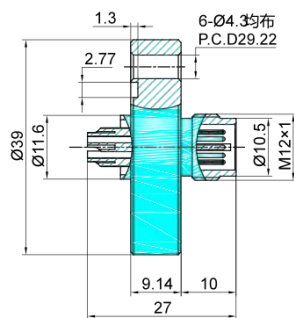

#### 技术参数 Specification

封接方式 Sealing Form	陶瓷钎焊 Ceramic Brazing
针数 Number of pins	8 Pins
端口标准 Port Standards	IEC 61076-2-101 焊接针 Solderable Pin
最大电流 Max Current	1 A
最大电压 Max Voltage	1 KV
绝缘阻抗 Insulation resistance	$\geq 1 \times 10^9 \Omega$
漏气率 Leakage Rate	$\leq 5 \times 10^{-13} \text{ Pa} \cdot \text{m}^3/\text{s}$
耐温 Temperature Resistance	-271°C~600 °C
耐气压 Pressure Tolerance	10 Bar
金属材料 Material	可伐/不锈钢 Kovar/SS

## 多针系列 Multi-pin Series — MIL-DTL 5015

MIL-DTL 5015系列多针馈通采用螺纹连接，提供可靠的机械锁定。端口形式一端为标准多针接口，另一端为光杆。安装密封方式，根据用户需求，可以为焊接，CF法兰，KF法兰，非标法兰等。

The MIL-DTL 5015 Series multi-pin feedthroughs feature threaded connections that provide reliable mechanical locking. The port form is a standard multi-pin interface at one end and a rod at the other end. The installation sealing method can be welding, CF flange, KF flange, non-standard flange, etc. according to user's need.

### ADS-FT-5015-4PIN-3KV-CF16

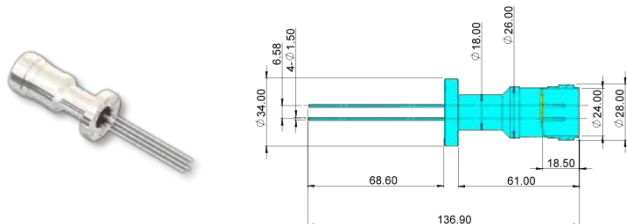

#### 技术参数 Specification

封接方式 Sealing Form	陶瓷钎焊 Ceramic Brazing
针数 Number of pins	4 Pins
端口标准 Port Standards	MIL-DTL-5015 光杆 Rod
最大电流 Max Current	3 A
最大电压 Max Voltage	4 KV
绝缘阻抗 Insulation resistance	$\geq 1 \times 10^9 \Omega$
漏气率 Leakage Rate	$\leq 5 \times 10^{-13} \text{ Pa} \cdot \text{m}^3/\text{s}$
耐温 Temperature Resistance	-271°C~600 °C
耐气压 Pressure Tolerance	10 Bar
金属材料 Material	可伐/不锈钢 Kovar/SS

### ADS-FT-5015-4PIN-4KV-CF35

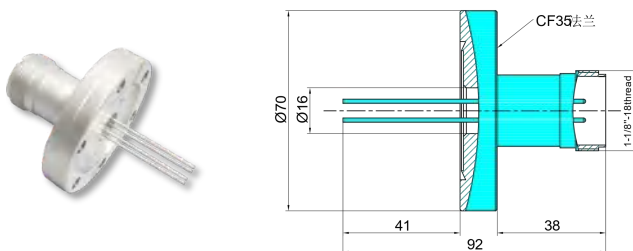

#### 技术参数 Specification

封接方式 Sealing Form	陶瓷钎焊 Ceramic Brazing
针数 Number of pins	4 Pins
端口标准 Port Standards	MIL-DTL-5015 光杆 Rod
最大电流 Max Current	3 A
最大电压 Max Voltage	4 KV
绝缘阻抗 Insulation resistance	$\geq 1 \times 10^9 \Omega$
漏气率 Leakage Rate	$\leq 5 \times 10^{-13} \text{ Pa} \cdot \text{m}^3/\text{s}$
耐温 Temperature Resistance	-271°C~600 °C
耐气压 Pressure Tolerance	10 Bar
金属材料 Material	可伐/不锈钢 Kovar/SS

## 多针系列 Multi-pin Series — IEC 60807

IEC 60807系列多针馈通具有梯形金属外壳，广泛用于控制通讯。端口形式一端为标准多针接口，另一端相同或者焊杯。安装密封方式，根据用户需求，可以为焊接，CF法兰，KF法兰，非标法兰等。

The IEC 60807 series multi-pin feedthroughs feature a trapezoidal metal housing and are widely used for control communications. The port form is a standard multi-pin interface at one end, and the other end is the same or a solder cup. The installation sealing method can be welding, CF flange, KF flange, non-standard flange, etc. according to user's need.

### ADS-FT-60807-9PIN-WD

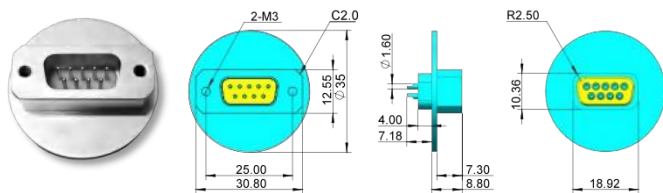

#### 技术参数 Specification

封接方式 Sealing Form	陶瓷钎焊 Ceramic Brazing
针数 Number of pins	9 Pins
端口标准 Port Standards	DE-9 焊接针 Solderable Pin
最大电流 Max Current	1.3 A
最大电压 Max Voltage	1 KV
绝缘阻抗 Insulation resistance	$\geq 1 \times 10^9 \Omega$
漏气率 Leakage Rate	$\leq 5 \times 10^{-13} \text{ Pa}\cdot\text{m}^3/\text{s}$
耐温 Temperature Resistance	-271°C~600 °C
耐气压 Pressure Tolerance	10 Bar
金属材料 Material	可伐/不锈钢 Kovar/Steel

### ADS-FT-60807-15PIN-WD

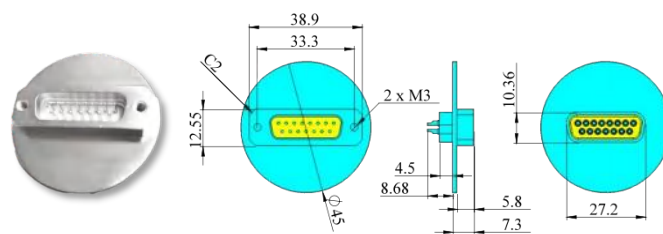

#### 技术参数 Specification

封接方式 Sealing Form	陶瓷钎焊 Ceramic Brazing
针数 Number of pins	15 Pins
端口标准 Port Standards	DE-15 焊接针 Solderable Pin
最大电流 Max Current	1.3 A
最大电压 Max Voltage	1 KV
绝缘阻抗 Insulation resistance	$\geq 1 \times 10^9 \Omega$
漏气率 Leakage Rate	$\leq 5 \times 10^{-13} \text{ Pa}\cdot\text{m}^3/\text{s}$
耐温 Temperature Resistance	-271°C~600 °C
耐气压 Pressure Tolerance	10 Bar
金属材料 Material	可伐/不锈钢 Kovar/Steel

### ADS-FT-60807-9PIN-DWD

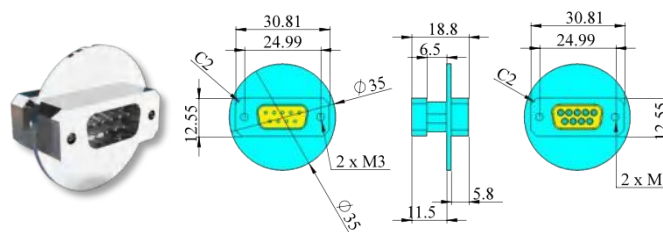

#### 技术参数 Specification

封接方式 Sealing Form	陶瓷钎焊 Ceramic Brazing
针数 Number of pins	9 Pins
端口标准 Port Standards	DE-9 DE-9
最大电流 Max Current	1.3 A
最大电压 Max Voltage	1 KV
绝缘阻抗 Insulation resistance	$\geq 1 \times 10^9 \Omega$
漏气率 Leakage Rate	$\leq 5 \times 10^{-13} \text{ Pa}\cdot\text{m}^3/\text{s}$
耐温 Temperature Resistance	-271°C~600 °C
耐气压 Pressure Tolerance	10 Bar
金属材料 Material	可伐/不锈钢 Kovar/Steel

## 多针系列 Multi-pin Series — IEC 60807

### ADS-FT-60807-15PIN-DWD

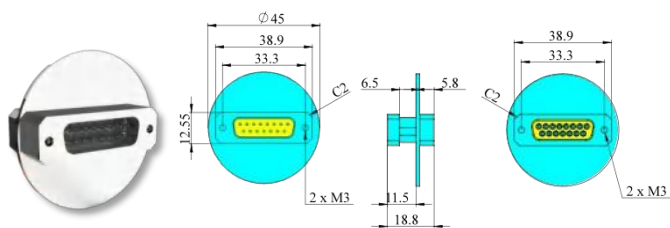

#### 技术参数 Specification

封接方式 Sealing Form	陶瓷钎焊 Ceramic Brazing
针数 Number of pins	15 Pins
端口标准 Port Standards	DE-15 DE-15
最大电流 Max Current	1.3 A
最大电压 Max Voltage	1 KV
绝缘阻抗 Insulation resistance	$\geq 1 \times 10^9 \Omega$
漏气率 Leakage Rate	$\leq 5 \times 10^{-13} \text{ Pa} \cdot \text{m}^3/\text{s}$
耐温 Temperature Resistance	-271°C~600 °C
耐气压 Pressure Tolerance	10 Bar
金属材料 Material	可伐/不锈钢 Kovar/Steel



带CF法兰，with CF flange



带KF法兰，with KF flange

## 耐高压系列 High Voltage Series

耐高压馈通用于大气与真空之间进行高电压直流或低频电信号传输。端口形式为标准接口、光杆、内螺纹、外螺纹、或用户定制。密封结构有CF法兰，KF法兰，非标法兰等。

High-voltage feedthroughs are used to transmit high voltage DC or low-frequency signals between the atmosphere and vacuum. Port form is standard interface, rod, internal thread, external thread, or customized by the user. The sealing structure includes CF flange, KF flange, non-standard flange or user customized interface, etc.

### ADS-FT-FC-12KV-CF16

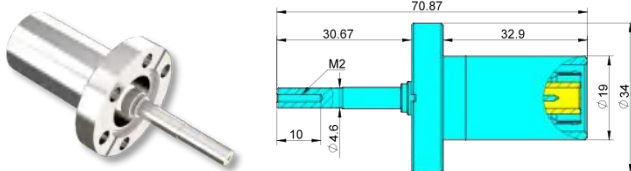

可延展为安捷伦相同接口  
Can be extended to the same interface as Agilent

#### 技术参数 Specification

封接方式 Sealing Form	陶瓷钎焊 Ceramic Brazing
针数 Number of pins	1 Pin
端口标准 Port Standards	SHV 内螺纹 Internal screw
最大电流 Max Current	4 A
最大电压 Max Voltage	12 KV
绝缘阻抗 Insulation resistance	$\geq 1 \times 10^9 \Omega$
漏气率 Leakage Rate	$\leq 5 \times 10^{-13} \text{ Pa}\cdot\text{m}^3/\text{s}$
耐高温 Temperature Resistance	-271°C~600 °C
耐气压 Pressure Tolerance	10 Bar
金属材料 Material	可伐/不锈钢 Kovar/SS

### ADS-FT-SHV-7KV-WD

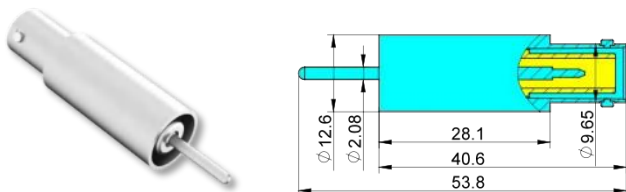

#### 技术参数 Specification

封接方式 Sealing Form	陶瓷钎焊 Ceramic Brazing
针数 Number of pins	1 Pin
端口标准 Port Standards	SHV 光杆 Rod
最大电流 Max Current	6 A
最大电压 Max Voltage	7 KV
绝缘阻抗 Insulation resistance	$\geq 1 \times 10^9 \Omega$
漏气率 Leakage Rate	$\leq 5 \times 10^{-13} \text{ Pa}\cdot\text{m}^3/\text{s}$
耐高温 Temperature Resistance	-271°C~600 °C
耐气压 Pressure Tolerance	10 Bar
金属材料 Material	可伐/不锈钢 Kovar/SS

### ADS-FT-DSHV-7KV-WD

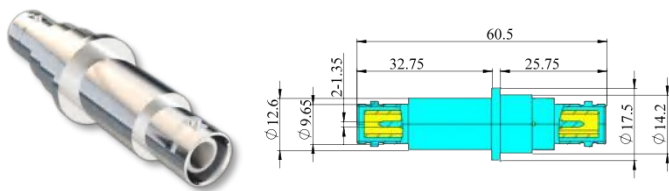

#### 技术参数 Specification

封接方式 Sealing Form	陶瓷钎焊 Ceramic Brazing
针数 Number of pins	1 Pin
端口标准 Port Standards	SHV SHV
最大电流 Max Current	6 A
最大电压 Max Voltage	7 KV
绝缘阻抗 Insulation resistance	$\geq 1 \times 10^9 \Omega$
漏气率 Leakage Rate	$\leq 5 \times 10^{-13} \text{ Pa}\cdot\text{m}^3/\text{s}$
耐高温 Temperature Resistance	-271°C~600 °C
耐气压 Pressure Tolerance	10 Bar
金属材料 Material	可伐/不锈钢 Kovar/SS

## 耐高压系列 High Voltage Series

### ADS-FT-S-7KV-300A-CF16

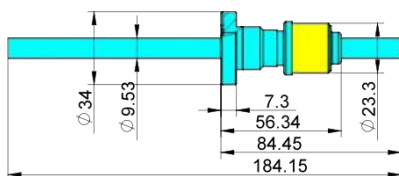

#### 技术参数 Specification

封接方式 Sealing Form	陶瓷钎焊 Ceramic Brazing
针数 Number of pins	1 Pin
端口标准 Port Standards	光杆 Rod 300 A(铜, Copper) 150A(钼, Molybdenum) 95A(镍, Nickel) 30A(不锈钢, 316L)
最大电流 Max Current	
最大电压 Max Voltage	7 KV
绝缘阻抗 Insulation resistance	$\geq 1 \times 10^9 \Omega$
漏气率 Leakage Rate	$\leq 5 \times 10^{-13} \text{ Pa} \cdot \text{m}^3/\text{s}$
耐温 Temperature Resistance	-271°C~600 °C
耐气压 Pressure Tolerance	10 Bar
金属材料 Material	可伐/不锈钢/无氧铜 Kovar/SS/OFHC

### ADS-FT-S-7KV-300A-KF16

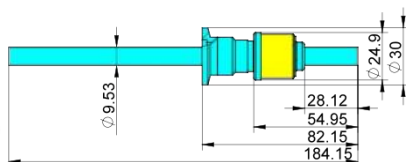

#### 技术参数 Specification

封接方式 Sealing Form	陶瓷钎焊 Ceramic Brazing
针数 Number of pins	1 Pin
端口标准 Port Standards	光杆 Rod 300 A(铜, Copper) 150A(钼, Molybdenum) 95A(镍, Nickel) 30A(不锈钢, 316L)
最大电流 Max Current	
最大电压 Max Voltage	7 KV
绝缘阻抗 Insulation resistance	$\geq 1 \times 10^9 \Omega$
漏气率 Leakage Rate	$\leq 5 \times 10^{-13} \text{ Pa} \cdot \text{m}^3/\text{s}$
耐温 Temperature Resistance	-271°C~600 °C
耐气压 Pressure Tolerance	10 Bar
金属材料 Material	可伐/不锈钢/无氧铜 Kovar/SS/OFHC

### ADS-FT-12KV-180A-WD

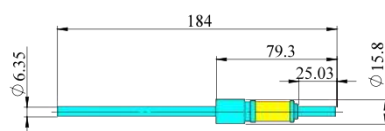

#### 技术参数 Specification

封接方式 Sealing Form	陶瓷钎焊 Ceramic Brazing
针数 Number of pins	1 Pin
端口标准 Port Standards	光杆 Rod 180 A(铜, Copper) 90A(钼, Molybdenum) 56A(镍, Nickel) 15A(不锈钢, 316L)
最大电流 Max Current	
最大电压 Max Voltage	12 KV
绝缘阻抗 Insulation resistance	$\geq 1 \times 10^9 \Omega$
漏气率 Leakage Rate	$\leq 5 \times 10^{-13} \text{ Pa} \cdot \text{m}^3/\text{s}$
耐温 Temperature Resistance	-271°C~600 °C
耐气压 Pressure Tolerance	10 Bar
金属材料 Material	可伐/不锈钢/无氧铜 Kovar/SS/OFHC

### ADS-FT-30KV-80A-CF16-HT

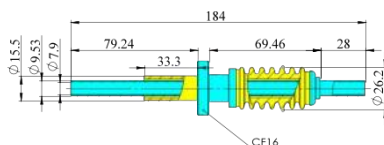

#### 技术参数 Specification

封接方式 Sealing Form	陶瓷钎焊 Ceramic Brazing
针数 Number of pins	1 Pin
端口标准 Port Standards	空心管 Hollow tube
最大电流 Max Current	80A
最大电压 Max Voltage	30KV
绝缘阻抗 Insulation resistance	$\geq 1 \times 10^9 \Omega$
漏气率 Leakage Rate	$\leq 5 \times 10^{-13} \text{ Pa} \cdot \text{m}^3/\text{s}$
耐温 Temperature Resistance	-271°C~600 °C
耐气压 Pressure Tolerance	10 Bar
金属材料 Material	可伐/不锈钢/无氧铜 Kovar/SS/OFHC

## 耐高压系列 High Voltage Series

### ADS-FT-FM-30KV-70A-CF16

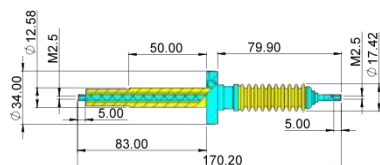

#### 技术参数 Specification

封接方式 Sealing Form	陶瓷钎焊 Ceramic Brazing
针数 Number of pins	1 Pin
端口标准 Port Standards	外螺纹 External screw 内螺纹 Internal thread
最大电流 Max Current	70 A
最大电压 Max Voltage	30 KV
绝缘阻抗 Insulation resistance	$\geq 1 \times 10^9 \Omega$
漏气率 Leakage Rate	$\leq 5 \times 10^{-13} \text{ Pa}\cdot\text{m}^3/\text{s}$
耐温 Temperature Resistance	-271°C~600 °C
耐气压 Pressure Tolerance	10 Bar
金属材料 Material	可伐/不锈钢/无氧铜 Kovar/SS/OFHC

### ADS-FT-FM-12KV-180A-CF16

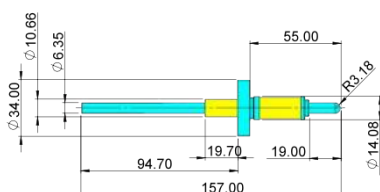

#### 技术参数 Specification

封接方式 Sealing Form	陶瓷钎焊 Ceramic Brazing
针数 Number of pins	1 Pin
端口标准 Port Standards	光杆 Rod
最大电流 Max Current	180 A(铜, Copper) 90A(钼, Molybdenum) 56A(镍, Nickel) 15A(不锈钢, 316L)
最大电压 Max Voltage	12 KV
绝缘阻抗 Insulation resistance	$\geq 1 \times 10^9 \Omega$
漏气率 Leakage Rate	$\leq 5 \times 10^{-13} \text{ Pa}\cdot\text{m}^3/\text{s}$
耐温 Temperature Resistance	-271°C~600 °C
耐气压 Pressure Tolerance	10 Bar
金属材料 Material	可伐/不锈钢/无氧铜 Kovar/SS/OFHC

### ADS-FT-FM-2PIN-12KV-180A-CF35

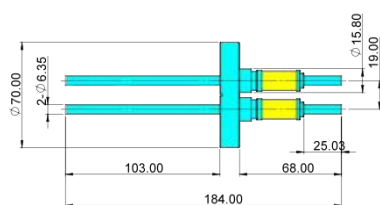

#### 技术参数 Specification

封接方式 Sealing Form	陶瓷钎焊 Ceramic Brazing
针数 Number of pins	1 Pin
端口标准 Port Standards	光杆 Rod
最大电流 Max Current	180 A(铜, Copper) 90A(钼, Molybdenum) 56A(镍, Nickel) 15A(不锈钢, 316L)
最大电压 Max Voltage	12 KV
绝缘阻抗 Insulation resistance	$\geq 1 \times 10^9 \Omega$
漏气率 Leakage Rate	$\leq 5 \times 10^{-13} \text{ Pa}\cdot\text{m}^3/\text{s}$
耐温 Temperature Resistance	-271°C~600 °C
耐气压 Pressure Tolerance	10 Bar
金属材料 Material	可伐/不锈钢/无氧铜 Kovar/SS/OFHC

### ADS-FT-2PIN-30KV-30A-CF40

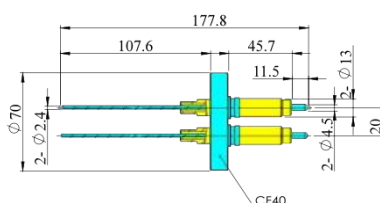

#### 技术参数 Specification

封接方式 Sealing Form	陶瓷钎焊 Ceramic Brazing
针数 Number of pins	2 Pins
端口标准 Port Standards	光杆
最大电流 Max Current	30A
最大电压 Max Voltage	30KV
绝缘阻抗 Insulation resistance	$\geq 1 \times 10^9 \Omega$
漏气率 Leakage Rate	$\leq 5 \times 10^{-13} \text{ Pa}\cdot\text{m}^3/\text{s}$
耐温 Temperature Resistance	-271°C~600 °C
耐气压 Pressure Tolerance	10 Bar
金属材料 Material	可伐/不锈钢/无氧铜 Kovar/SS/OFHC

## 耐高压系列 High Voltage Series

### ADS-FT-120KV-150A-CF100

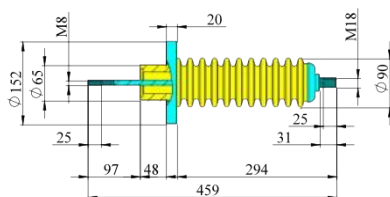

#### 技术参数 Specification

封接方式 Sealing Form	陶瓷钎焊 Ceramic Brazing
针数 Number of pins	1 Pin
端口标准 Port Standards	M18 M8
最大电流 Max Current	150 A
最大电压 Max Voltage	120KV
绝缘阻抗 Insulation resistance	$\geq 1 \times 10^9 \Omega$
漏气率 Leakage Rate	$\leq 5 \times 10^{-13} \text{ Pa}\cdot\text{m}^3/\text{s}$
耐温 Temperature Resistance	-271°C~600 °C
耐气压 Pressure Tolerance	10 Bar
金属材料 Material	可伐/不锈钢/无氧铜 Kovar/SS/OFHC

### ADS-FT-100KV-60A-ISO200

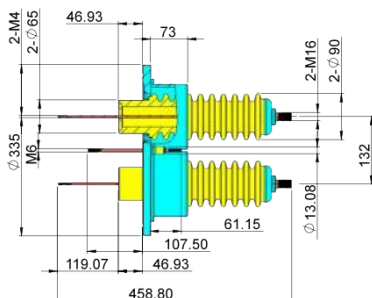

#### 技术参数 Specification

封接方式 Sealing Form	陶瓷钎焊 Ceramic Brazing
针数 Number of pins	2 Pins
端口标准 Port Standards	M16 M8
最大电流 Max Current	60 A
最大电压 Max Voltage	100 KV
绝缘阻抗 Insulation resistance	$\geq 1 \times 10^9 \Omega$
漏气率 Leakage Rate	$\leq 5 \times 10^{-13} \text{ Pa}\cdot\text{m}^3/\text{s}$
耐温 Temperature Resistance	-271°C~600 °C
耐气压 Pressure Tolerance	10 Bar
金属材料 Material	可伐/不锈钢/无氧铜 Kovar/SS/OFHC

### ADS-FT-100KV-150A-ISO200

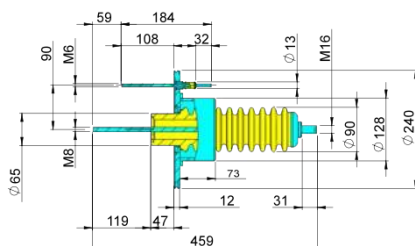

#### 技术参数 Specification

封接方式 Sealing Form	陶瓷钎焊 Ceramic Brazing
针数 Number of pins	1 Pin
端口标准 Port Standards	M16 M8
最大电流 Max Current	150 A
最大电压 Max Voltage	100 KV
绝缘阻抗 Insulation resistance	$\geq 1 \times 10^9 \Omega$
漏气率 Leakage Rate	$\leq 5 \times 10^{-13} \text{ Pa}\cdot\text{m}^3/\text{s}$
耐温 Temperature Resistance	-271°C~600 °C
耐气压 Pressure Tolerance	10 Bar
金属材料 Material	可伐/不锈钢/无氧铜 Kovar/SS/OFHC

### ADS-FT-150KV-150A-CF250

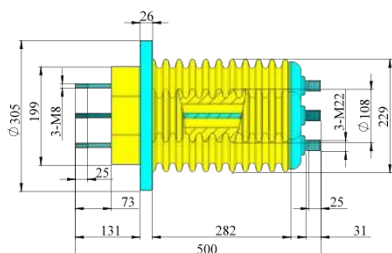

#### 技术参数 Specification

封接方式 Sealing Form	陶瓷钎焊 Ceramic Brazing
针数 Number of pins	3 Pins
端口标准 Port Standards	M22 M8
最大电流 Max Current	150A
最大电压 Max Voltage	150KV (对地 To the ground)
绝缘阻抗 Insulation resistance	$\geq 1 \times 10^9 \Omega$
漏气率 Leakage Rate	$\leq 5 \times 10^{-13} \text{ Pa}\cdot\text{m}^3/\text{s}$
耐温 Temperature Resistance	-271°C~600 °C
耐气压 Pressure Tolerance	10 Bar
金属材料 Material	可伐/不锈钢/无氧铜 Kovar/SS/OFHC

## 耐高压系列 High Voltage Series

### ADS-FT-120KV-CF100

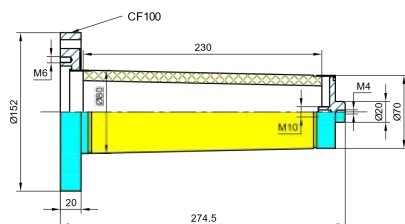

#### 技术参数 Specification

封接方式 Sealing Form	陶瓷钎焊 Ceramic Brazing
针数 Number of pins	1 Pin
端口标准 Port Standards	M4 M10
最大电流 Max Current	15 A
最大电压 Max Voltage	120 KV
绝缘阻抗 Insulation resistance	$\geq 1 \times 10^9 \Omega$
漏气率 Leakage Rate	$\leq 5 \times 10^{-13} \text{ Pa} \cdot \text{m}^3/\text{s}$
耐温 Temperature Resistance	-271°C~600 °C
耐气压 Pressure Tolerance	10 Bar
金属材料 Material	可伐/不锈钢 Kovar/SS

## 大电流系列 High Current Series

大电流馈通是用于大气与真空之间进行大电流直流或低频信号传输的接插件。一端内导体为标准接口或者用户定制接口，另一端内导体为光杆、内螺纹、外螺纹、或用户定制接口。密封结构有CF法兰，KF法兰，非标法兰或用户定制接口等。

High current Feedthrough is a connector used for transmitting high current DC or low-frequency signals between atmosphere and vacuum. One end of the inner and outer conductors is a standard interface or a user customized interface, while the other end of the inner conductor is a rod, internal thread, external thread, or a user customized interface. The sealing structure includes CF flange, KF flange, non-standard flange or user customized interface, etc.

### ADS-HCFT-3PIN-120A

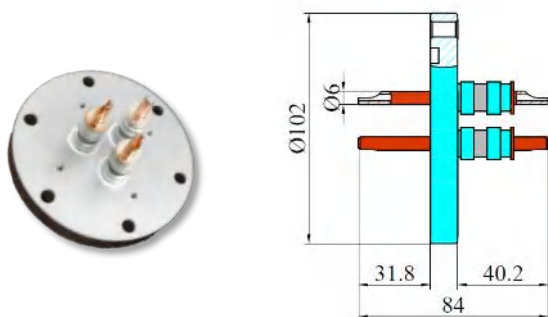

#### 技术参数 Specification

封接方式 Sealing Form	陶瓷钎焊 Ceramic Brazing
针数 Number of pins	3 Pins
端口标准 Port Standards	焊接针 Solderable Pin
最大电流 Max Current	120 A
最大电压 Max Voltage	3 KV
绝缘阻抗 Insulation resistance	$\geq 1 \times 10^9 \Omega$
漏气率 Leakage Rate	$\leq 5 \times 10^{-13} \text{ Pa} \cdot \text{m}^3/\text{s}$
耐温 Temperature Resistance	-271°C~600°C
耐气压 Pressure Tolerance	10 Bar
金属材料 Material	可伐/不锈钢/无氧铜 Kovar/SS/OFHC

### ADS-FT-S-7KV-300A-CF16

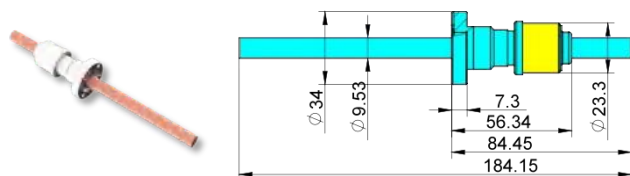

#### 技术参数 Specification

封接方式 Sealing Form	陶瓷钎焊 Ceramic Brazing
针数 Number of pins	1 Pin
端口标准 Port Standards	光杆 Rod
最大电流 Max Current	300 A
最大电压 Max Voltage	7 KV
绝缘阻抗 Insulation resistance	$\geq 1 \times 10^9 \Omega$
漏气率 Leakage Rate	$\leq 5 \times 10^{-13} \text{ Pa} \cdot \text{m}^3/\text{s}$
耐温 Temperature Resistance	-271°C~600 °C
耐气压 Pressure Tolerance	10 Bar
金属材料 Material	可伐/不锈钢/无氧铜 Kovar/SS/OFHC

## 大电流系列 High Current Series

### ADS-FT-S-7KV-300A-KF16

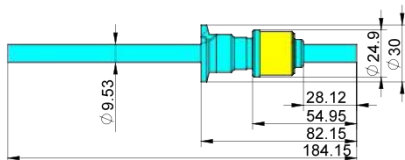

#### 技术参数 Specification

封接方式 Sealing Form	陶瓷钎焊 Ceramic Brazing
针数 Number of pins	1 Pin
端口标准 Port Standards	光杆 Rod
最大电流 Max Current	300 A
最大电压 Max Voltage	7 KV
绝缘阻抗 Insulation resistance	$\geq 1 \times 10^9 \Omega$
漏气率 Leakage Rate	$\leq 5 \times 10^{-13} \text{ Pa}\cdot\text{m}^3/\text{s}$
耐温 Temperature Resistance	-271°C~600 °C
耐气压 Pressure Tolerance	10 Bar
金属材料 Material	可伐/不锈钢/无氧铜 Kovar/SS/OFHC

### ADS-FT-12KV-130A-WD

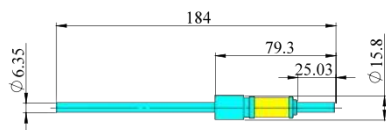
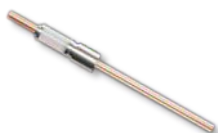

#### 技术参数 Specification

封接方式 Sealing Form	陶瓷钎焊 Ceramic Brazing
针数 Number of pins	1 Pin
端口标准 Port Standards	光杆 Rod
最大电流 Max Current	130 A
最大电压 Max Voltage	12 KV
绝缘阻抗 Insulation resistance	$\geq 1 \times 10^9 \Omega$
漏气率 Leakage Rate	$\leq 5 \times 10^{-13} \text{ Pa}\cdot\text{m}^3/\text{s}$
耐温 Temperature Resistance	-271°C~600 °C
耐气压 Pressure Tolerance	10 Bar
金属材料 Material	可伐/不锈钢/无氧铜 Kovar/SS/OFHC

### ADS-FT-30KV-80A-CF16-HT

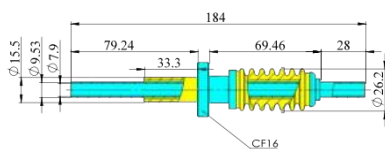

#### 技术参数 Specification

封接方式 Sealing Form	陶瓷钎焊 Ceramic Brazing
针数 Number of pins	1 Pin
端口标准 Port Standards	空心管 Hollow tube
最大电流 Max Current	80A
最大电压 Max Voltage	30KV
绝缘阻抗 Insulation resistance	$\geq 1 \times 10^9 \Omega$
漏气率 Leakage Rate	$\leq 5 \times 10^{-13} \text{ Pa}\cdot\text{m}^3/\text{s}$
耐温 Temperature Resistance	-271°C~600 °C
耐气压 Pressure Tolerance	10 Bar
金属材料 Material	可伐/不锈钢/无氧铜 Kovar/SS/OFHC

### ADS-FT-FM-30KV-70A-CF16

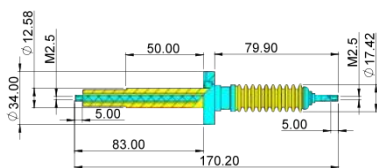

#### 技术参数 Specification

封接方式 Sealing Form	陶瓷钎焊 Ceramic Brazing
针数 Number of pins	1 Pin
端口标准 Port Standards	外螺纹 External screw 内螺纹 Internal thread
最大电流 Max Current	70 A
最大电压 Max Voltage	30 KV
绝缘阻抗 Insulation resistance	$\geq 1 \times 10^9 \Omega$
漏气率 Leakage Rate	$\leq 5 \times 10^{-13} \text{ Pa}\cdot\text{m}^3/\text{s}$
耐温 Temperature Resistance	-271°C~600 °C
耐气压 Pressure Tolerance	10 Bar
金属材料 Material	可伐/不锈钢/无氧铜 Kovar/SS/OFHC

## 大电流系列 High Current Series

### ADS-FT-FM-12KV-130A-CF16

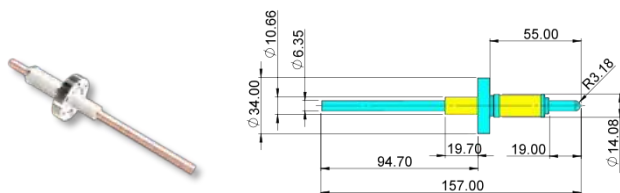

#### 技术参数 Specification

封接方式 Sealing Form	陶瓷钎焊 Ceramic Brazing
针数 Number of pins	1 Pin
端口标准 Port Standards	光杆 Rod
最大电流 Max Current	130 A
最大电压 Max Voltage	12 KV
绝缘阻抗 Insulation resistance	$\geq 1 \times 10^9 \Omega$
漏气率 Leakage Rate	$\leq 5 \times 10^{-13} \text{ Pa}\cdot\text{m}^3/\text{s}$
耐温 Temperature Resistance	-271°C~600 °C
耐气压 Pressure Tolerance	10 Bar
金属材料 Material	可伐/不锈钢/无氧铜 Kovar/SS/OFHC

### ADS-FT-FM-2PIN-12KV-130A-CF35

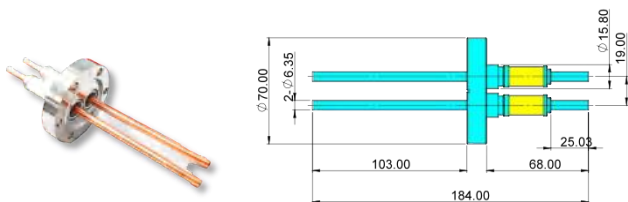

#### 技术参数 Specification

封接方式 Sealing Form	陶瓷钎焊 Ceramic Brazing
针数 Number of pins	1 Pin
端口标准 Port Standards	光杆 Rod
最大电流 Max Current	130 A
最大电压 Max Voltage	12 KV
绝缘阻抗 Insulation resistance	$\geq 1 \times 10^9 \Omega$
漏气率 Leakage Rate	$\leq 5 \times 10^{-13} \text{ Pa}\cdot\text{m}^3/\text{s}$
耐温 Temperature Resistance	-271°C~600 °C
耐气压 Pressure Tolerance	10 Bar
金属材料 Material	可伐/不锈钢/无氧铜 Kovar/SS/OFHC

### ADS-FT-2PIN-30KV-30A-CF40

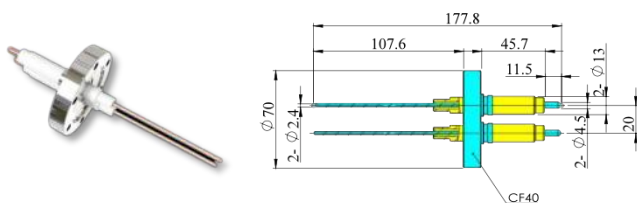

#### 技术参数 Specification

封接方式 Sealing Form	陶瓷钎焊 Ceramic Brazing
针数 Number of pins	2 Pins
端口标准 Port Standards	光杆
最大电流 Max Current	30A
最大电压 Max Voltage	30KV
绝缘阻抗 Insulation resistance	$\geq 1 \times 10^9 \Omega$
漏气率 Leakage Rate	$\leq 5 \times 10^{-13} \text{ Pa}\cdot\text{m}^3/\text{s}$
耐温 Temperature Resistance	-271°C~600 °C
耐气压 Pressure Tolerance	10 Bar
金属材料 Material	可伐/不锈钢/无氧铜 Kovar/SS/OFHC

### ADS-FT-120KV-150A-CF100

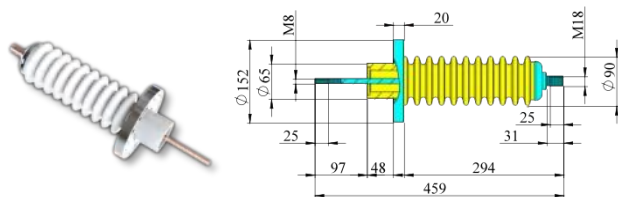

#### 技术参数 Specification

封接方式 Sealing Form	陶瓷钎焊 Ceramic Brazing
针数 Number of pins	1 Pin
端口标准 Port Standards	M18 M8
最大电流 Max Current	150 A
最大电压 Max Voltage	120KV
绝缘阻抗 Insulation resistance	$\geq 1 \times 10^9 \Omega$
漏气率 Leakage Rate	$\leq 5 \times 10^{-13} \text{ Pa}\cdot\text{m}^3/\text{s}$
耐温 Temperature Resistance	-271°C~600 °C
耐气压 Pressure Tolerance	10 Bar
金属材料 Material	可伐/不锈钢/无氧铜 Kovar/SS/OFHC

## 大电流系列 High Current Series

### ADS-FT-100KV-60A-ISO200

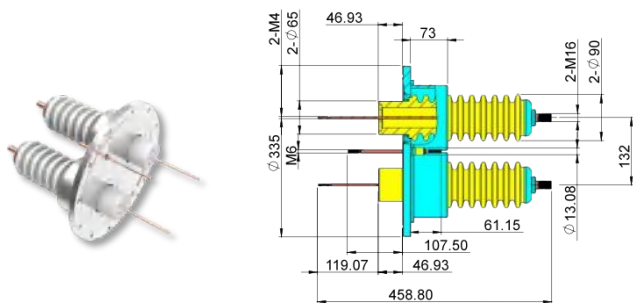

#### 技术参数 Specification

封接方式 Sealing Form	陶瓷钎焊 Ceramic Brazing
针数 Number of pins	2 Pins
端口标准 Port Standards	M16 M8
最大电流 Max Current	60 A
最大电压 Max Voltage	100 KV
绝缘阻抗 Insulation resistance	$\geq 1 \times 10^9 \Omega$
漏气率 Leakage Rate	$\leq 5 \times 10^{-13} \text{ Pa}\cdot\text{m}^3/\text{s}$
耐温 Temperature Resistance	-271°C~600 °C
耐气压 Pressure Tolerance	10 Bar
金属材料 Material	可伐/不锈钢/无氧铜 Kovar/SS/OFHC

### ADS-FT-100KV-150A-ISO200

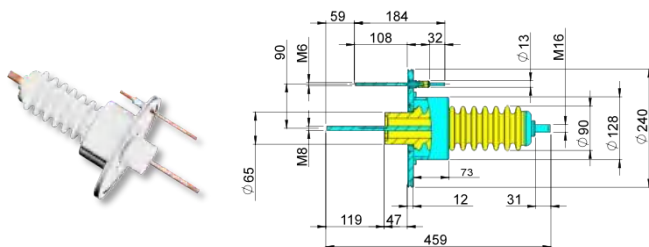

#### 技术参数 Specification

封接方式 Sealing Form	陶瓷钎焊 Ceramic Brazing
针数 Number of pins	1 Pin
端口标准 Port Standards	M16 M8
最大电流 Max Current	150 A
最大电压 Max Voltage	100 KV
绝缘阻抗 Insulation resistance	$\geq 1 \times 10^9 \Omega$
漏气率 Leakage Rate	$\leq 5 \times 10^{-13} \text{ Pa}\cdot\text{m}^3/\text{s}$
耐温 Temperature Resistance	-271°C~600 °C
耐气压 Pressure Tolerance	10 Bar
金属材料 Material	可伐/不锈钢/无氧铜 Kovar/SS/OFHC

### ADS-FT-150KV-150A-CF250

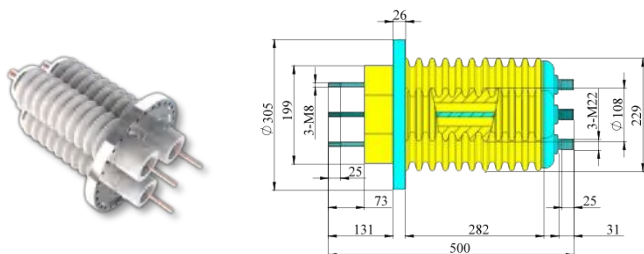

#### 技术参数 Specification

封接方式 Sealing Form	陶瓷钎焊 Ceramic Brazing
针数 Number of pins	3 Pins
端口标准 Port Standards	M22 M8
最大电流 Max Current	150A
最大电压 Max Voltage	150KV (对地 To the ground)
绝缘阻抗 Insulation resistance	$\geq 1 \times 10^9 \Omega$
漏气率 Leakage Rate	$\leq 5 \times 10^{-13} \text{ Pa}\cdot\text{m}^3/\text{s}$
耐温 Temperature Resistance	-271°C~600 °C
耐气压 Pressure Tolerance	10 Bar
金属材料 Material	可伐/不锈钢/无氧铜 Kovar/SS/OFHC

## 真空隔离器系列 Vacuum Isolator Series

真空隔离器是用来在真空中传输气、液，或者贯穿电缆，且又电隔离的部件。一般一端内导体为标准接口或者用户定制接口，另一端内导体为光杆、内螺纹、外螺纹、或用户定制接口。密封结构有CF法兰，KF法兰，非标法兰或用户定制接口等。

Vacuum isolator is a component used to transmit gas, liquid, or penetrate cables in a vacuum and to electrically isolate them. One end of the inner and outer conductors is a standard interface or a user customized interface, while the other end of the inner conductor is a rod, internal thread, external thread, or a user customized interface. The sealing structure includes CF flange, KF flange, non-standard flange or user customized interface, etc.

### ADS-FT-VI-13KV-01

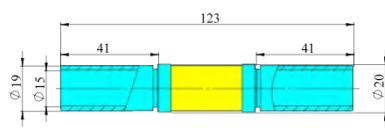

#### 技术参数 Specification

封接方式 Sealing Form	陶瓷钎焊 Ceramic Brazing
端口标准 Port Standards	空心管 Hollow tube
最大电压 Max Voltage	13 KV
绝缘阻抗 Insulation resistance	$\geq 1 \times 10^9 \Omega$
漏气率 Leakage Rate	$\leq 5 \times 10^{-13} \text{ Pa}\cdot\text{m}^3/\text{s}$
耐温 Temperature Resistance	-271°C~600 °C
耐气压 Pressure Tolerance	10 Bar
金属材料 Material	可伐/不锈钢 Kovar/SS

### ADS-FT-VI-13KV-02

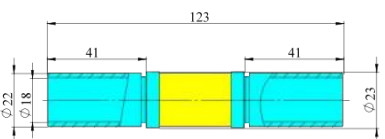

#### 技术参数 Specification

封接方式 Sealing Form	陶瓷钎焊 Ceramic Brazing
端口标准 Port Standards	空心管 Hollow tube
最大电压 Max Voltage	13 KV
绝缘阻抗 Insulation resistance	$\geq 1 \times 10^9 \Omega$
漏气率 Leakage Rate	$\leq 5 \times 10^{-13} \text{ Pa}\cdot\text{m}^3/\text{s}$
耐温 Temperature Resistance	-271°C~600 °C
耐气压 Pressure Tolerance	10 Bar
金属材料 Material	可伐/不锈钢 Kovar/SS

### ADS-FT-RGU-15KV

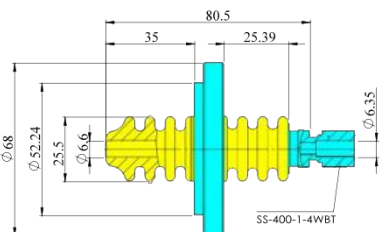

#### 技术参数 Specification

封接方式 Sealing Form	陶瓷钎焊 Ceramic Brazing
端口标准 Port Standards	SS-400-1-4WBT
最大电压 Max Voltage	15 KV
绝缘阻抗 Insulation resistance	$\geq 1 \times 10^9 \Omega$
漏气率 Leakage Rate	$\leq 5 \times 10^{-13} \text{ Pa}\cdot\text{m}^3/\text{s}$
耐温 Temperature Resistance	-271°C~600 °C
耐气压 Pressure Tolerance	10 Bar
金属材料 Material	可伐/不锈钢 Kovar/SS

## 真空隔离器系列 Vacuum Isolator Series

### ADS-FT-VI-6KV-KF40

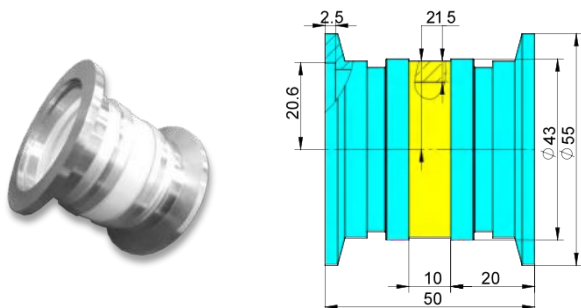

#### 技术参数 Specification

封接方式 Sealing Form	陶瓷钎焊 Ceramic Brazing
端口标准 Port Standards	KF40
最大电压 Max Voltage	6 KV
绝缘阻抗 Insulation resistance	$\geq 1 \times 10^9 \Omega$
漏气率 Leakage Rate	$\leq 5 \times 10^{-13} \text{ Pa} \cdot \text{m}^3/\text{s}$
耐温 Temperature Resistance	-271°C~600 °C
耐气压 Pressure Tolerance	10 Bar
金属材料 Material	可伐/不锈钢 Kovar/SS

### ADS-FT-VI-13KV-CF100

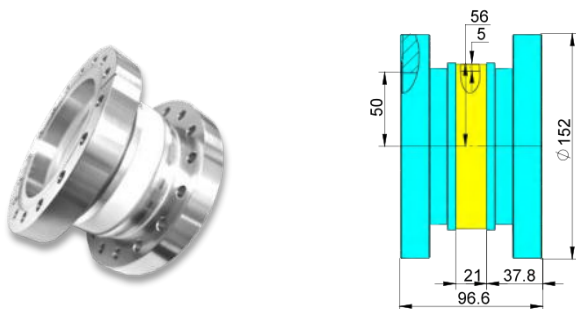

#### 技术参数 Specification

封接方式 Sealing Form	陶瓷钎焊 Ceramic Brazing
端口标准 Port Standards	CF100
最大电压 Max Voltage	13 KV
绝缘阻抗 Insulation resistance	$\geq 1 \times 10^9 \Omega$
漏气率 Leakage Rate	$\leq 5 \times 10^{-13} \text{ Pa} \cdot \text{m}^3/\text{s}$
耐温 Temperature Resistance	-271°C~600 °C
耐气压 Pressure Tolerance	10 Bar
金属材料 Material	可伐/不锈钢 Kovar/SS

### ADS-FT-VI-13KV-KF100

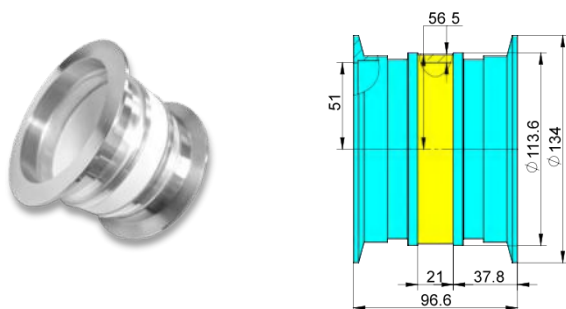

#### 技术参数 Specification

封接方式 Sealing Form	陶瓷钎焊 Ceramic Brazing
端口标准 Port Standards	KF100
最大电压 Max Voltage	13 KV
绝缘阻抗 Insulation resistance	$\geq 1 \times 10^9 \Omega$
漏气率 Leakage Rate	$\leq 5 \times 10^{-13} \text{ Pa} \cdot \text{m}^3/\text{s}$
耐温 Temperature Resistance	-271°C~600 °C
耐气压 Pressure Tolerance	10 Bar
金属材料 Material	可伐/不锈钢 Kovar/SS

## 真空观察窗系列

### Vacuum Window Series

真空观察窗是安装在真空设备上的特殊光学组件，通过蓝宝石、金刚石、石英玻璃等材料实现光波穿透观测。真空观察窗传输紫外线至红外线（400-1600nm）波段的光波信号。根据不同应用场景，密封结构分为可拆卸式（氟橡胶O圈耐150°C）与不可拆卸式（金属封接耐450°C）两类。

A vacuum observation window is a special optical component mounted on a vacuum device that achieves light wave penetration observations through materials such as sapphire, diamond, quartz glass, etc. The vacuum observation window transmits light wave signals in the ultraviolet to infrared (400~1600 nm) bands. Sealed construction is divided into detachable (fluororubber O-ring resistant to 150°C) and non detachable (metal seal resistant to 450°C) types according to different application scenarios.

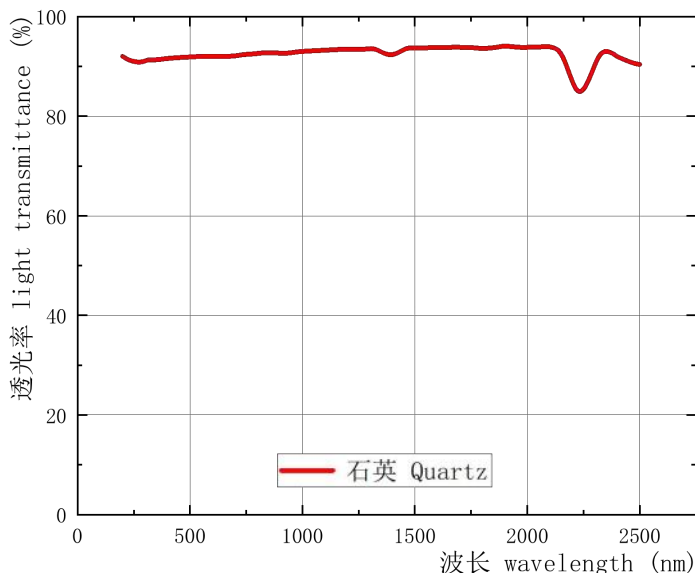

石英透光率 Quartz transmittance  
(标识代号 identification code: TM-QT-A)

## 真空观察窗系列 Vacuum Window Series

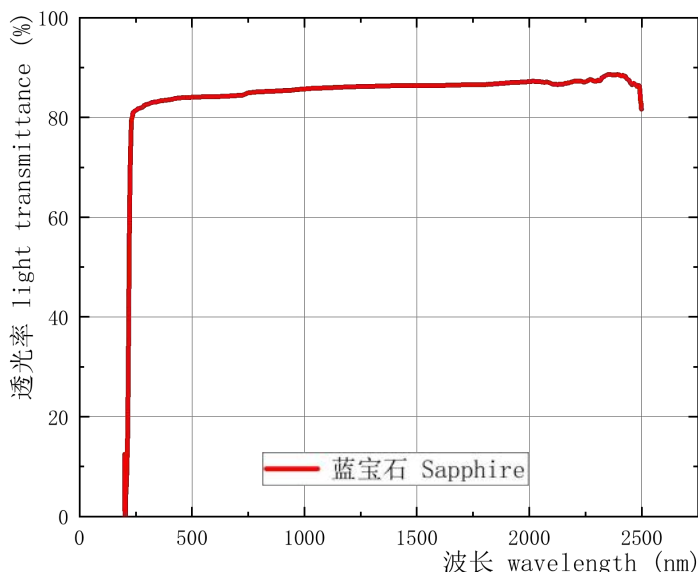

蓝宝石透光率 Sapphire transmittance  
(标识代号 identification code: TM-SP-A)

### ADS-VOW-CF16

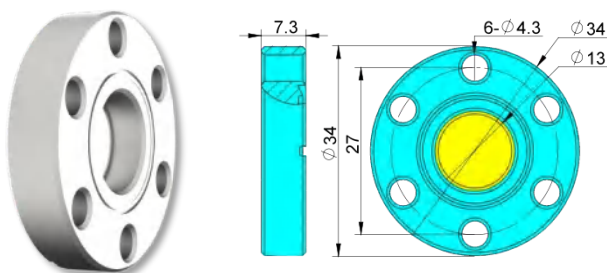

#### 技术参数 Specification

封接方式 Sealing Form	钎焊 Brazing
接口标准 Interface Standard	CF16
传输范围 Transmission Range	0.25-4um
耐温 Temperature Resistance	-271°C~450 °C
耐气压 Pressure Tolerance	10 Bar
漏气率 Leakage Rate	$\leq 5 \times 10^{-13} \text{ Pa} \cdot \text{m}^3/\text{s}$
窗材料 Material	蓝宝石/金刚石/石英 Sapphire/Diamond/Quartz
金属材料 Material	可伐/不锈钢 Kovar/SS

### ADS-VOW-OR16

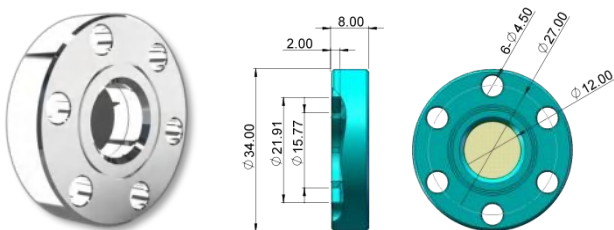

#### 技术参数 Specification

封接方式 Sealing Form	钎焊 Brazing
接口标准 Interface Standard	OR16
传输范围 Transmission Range	0.25-4um
耐温 Temperature Resistance	-271°C~450 °C
耐气压 Pressure Tolerance	10 Bar
漏气率 Leakage Rate	$\leq 5 \times 10^{-13} \text{ Pa} \cdot \text{m}^3/\text{s}$
窗材料 Material	蓝宝石/金刚石/石英 Sapphire/Diamond/Quartz
金属材料 Material	可伐/不锈钢 Kovar/SS

## 真空观察窗系列

### Vacuum Window Series

#### ADS-VOW-CF35

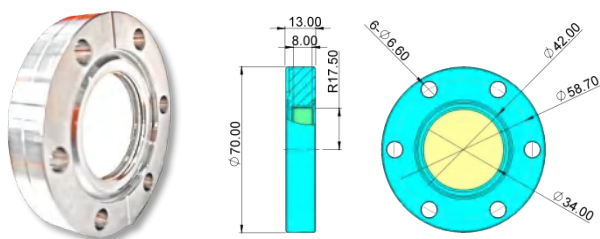

技术参数 Specification	
封接方式 Sealing Form	钎焊 Brazing
接口标准 Interface Standard	CF35
传输范围 Transmission Range	0.25-4um
耐温 Temperature Resistance	-271°C~450 °C
耐气压 Pressure Tolerance	10 Bar
漏气率 Leakage Rate	$\leq 5 \times 10^{-13} \text{ Pa} \cdot \text{m}^3/\text{s}$
窗材料 Material	蓝宝石/金刚石/石英 Sapphire/Diamond/Quartz
金属材料 Material	可伐/不锈钢 Kovar/SS

## 定制化产品 Customized Products

安德信科技根据用户需求，与用户合作，共同生产不同要求的各类馈通。产品覆盖半导体，PVD涂层，医疗，航空航天，深海勘探等高端设备领域。

ANDESUN Technology collaborates with users to produce various feedthroughs with different requirements based on their needs. The products cover high-end equipment fields such as semiconductors, PVD coatings, medical equipment, aerospace, and deep-sea exploration.



## 定制化产品 Customized Products



### 低磁导率 Low Magnetic Permeability

馈通的外导体和内导体可以采用无磁材料，磁导率低至1.03,对运行环境的磁场不会产生影响。

The outer and inner conductors of Feedthrough can be made of non-magnetic materials with a magnetic permeability as low as 1.03, which will not affect the magnetic field of the operating environment.



## 定制化产品 Customized Products

### » Gold Plating 镀金

馈通表面可以做镀金处理，提供更稳定的连接以及更高的信号质量。

The surface of vacuum connectors can be gold-plated to provide more stable connections and better signal quality.



## 注意事项 CAUTIONS

- 1.不可摔落；
- 2.不可急剧升温与降温；
- 3.在超过工作参数范围下使用可能造成损坏。

1. No dropping;
2. Rapid heating-up or cooling down must be avoided;
3. Using it beyond the specified working parameters may cause damage.

## 生产流程 Production Process

### 部件加工 Components Manufacturing



### 装配焊接 Assembly Welding



### 性能测试 Performance Testing



## 客户分布 Customer Distribution

公司研发馈通最初的目的是为国家重大工程服务，已经为我国上海光源等11个重大国家战略工程提供了质量可靠、性能优异的射频真空连接器以及延伸产品。目前，安德信科技真空馈通广泛应用在美国、法国、德国、英国、俄罗斯、中国等多国核电工程、带电粒子加速器、真空设备（真空泵、真空计、检漏仪、真空室、真空盒等）、半导体（镀膜与光刻）设备、真空镀膜设备、低温（低温制备、超导）系统、医疗设备、航空航天、石油勘探等领域。

The initial purpose of the company's research and development of Feedthrough was to serve national major projects, and it has provided reliable and high-performance RF vacuum connectors and extended products for 11 major national strategic projects in China, including Shanghai Light Source. ANDESUN Technology's feedthroughs have been widely used in nuclear power engineering, charged-particle accelerators, vacuum equipment (vacuum pumps, vacuum gauges, leak detectors, vacuum chambers, etc.), semiconductor (coating and photolithography) equipment, vacuum coating equipment, low-temperature (cryogenic preparation, superconducting) systems, medical equipment, aerospace, oil exploration and other fields.



## 行业评价和报道 Industry Evaluation And Reporting



### 工业和信息化部

### 科学技术成果登记证书

登记号：3392021Y1003

科技成果名称：高性能 Feedthrough 关键技术开发与应用

完成单位：南京大学、中国科学院上海高等研究院、江苏安德信超导加速器科技有限公司

南京质子源工程技术研究院有限公司、安德信微波设备有限公司

长安大学、中恒国信企业管理集团有限公司

登记机构：国家工业信息安全发展研究中心

二〇二一年五月二十六日

## 南京大学牵头成功解决了一项“卡脖子”技术

2021-08-06 14:08 南京大学 <https://news.eol.cn>

分享:

近日，工信部国家工业信息安全发展研究中心给南京大学、中国科学院上海高等研究院、江苏安德信超导加速器科技有限公司、南京质子源工程技术研究院有限公司、安德信微波设备有限公司、长安大学、中恒国信企业管理集团有限公司七家单位颁发了“高性能Feedthrough关键技术开发与应用”科学技术成果登记证书。这意味着由南京大学现代工程与应用科学学院南京质子源孙安团队与中国科学院上海高等研究院、安德信科技等七家单位联合，经过八年科技攻关，终于打破了国外技术垄断，填补了国内空白，解决了高性能Feedthrough这一“卡脖子”技术。

重大突破！南大牵头解决了一项“卡脖子”技术

魏科 | 原创



近日，工信部国家工业信息安全发展研究中心给南京大学、中国科学院上海高等研究院、江苏安德信超导加速器科技有限公司、南京质子源工程技术研究院有限公司、安德信微波设备有限公司、长安大学、中恒国信企业管理集团有限公司七家单位颁发了“高性能Feedthrough关键技术开发与应用”科学技术成果登记证书。这意味着由南京大学现代工程与应用科学学院南京质子源孙安团队与中国科学院上海高等研究院、安德信科技等七家单位联合，经过八年科技攻关，终于打破了国外技术垄断，填补了国内空白，解决了高性能Feedthrough这一“卡脖子”技术。

重大突破！南大牵头，解决了一项“卡脖子”技术！

魏科 | 原创 | 5图

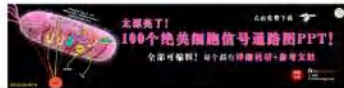

近日，工信部国家工业信息安全发展研究中心给南京大学、中国科学院上海高等研究院、江苏安德信超导加速器科技有限公司、南京质子源工程技术研究院有限公司、安德信微波设备有限公司、长安大学、中恒国信企业管理集团有限公司七家单位颁发了“高性能Feedthrough关键技术开发与应用”科学技术成果登记证书。这意味着由南京大学现代工程与应用科学学院南京质子源孙安团队与中国科学院上海高等研究院、安德信科技等七家单位联合，经过八年科技攻关，终于打破了国外技术垄断，填补了国内空白，解决了高性能Feedthrough这一“卡脖子”技术。

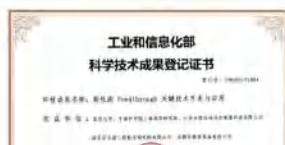

### 高校动态

- 延迟开学、暂不返校！多所高校发布最新校
- 中国海洋大学在海洋生态系统对全球变暖的
- 中国海洋大学在牛乳细胞外囊泡健康功能研
- 山东大学空间科学与物理学院本科生在天文
- 山东大学陶绪堂、赵昱教授团队在单晶光纤
- 北京印刷学院什么时候能改名？官方：已写
- 10260人！山东大学2021年本科生录取工作
- 华南理工大学携手广州花都探索乡村振兴与



### 重大突破：南京大学牵头，解决了一项“卡脖子”技术！

直观学机械 | 原创

点击上方蓝色李林直观学机械树可长期订阅我们

法律顾问：赵建英律师

近日，工信部国家工业信息安全发展研究中心给南京大学、中国科学院上海高等研究院、江苏安德信超导加速器科技有限公司、南京质子源工程技术研究院有限公司、安德信微波设备有限公司、长安大学、中恒国信企业管理集团有限公司七家单位颁发了“高性能Feedthrough关键技术开发与应用”科学技术成果登记证书。这意味着由南京大学现代工程与应用科学学院南京质子源孙安团队与中国科学院上海高等研究院、安德信科技等七家单位联合，经过八年科技攻关，终于打破了国外技术垄断，填补了国内空白，解决了高性能Feedthrough这一“卡脖子”技术。

### 微博正文

智慧科技迷  
8-10 08:35

【经过八年攻关，#南京大学打破一卡脖子技术##高性能Feedthrough技术获突破#】我国所用的高性能Feedthrough目前基本依赖进口，主要由日本的京瓷公司、美国的MPF等公司提供，价格昂贵，随时有被禁运的风险，而且供货周期长。近日，由南京大学孙安领导的联合研究团队经过八年科技攻关，终于打破了国外技术垄断，填补了国内空白，解决了高性能Feedthrough这一“卡脖子”技术。#每日创新发明# 智慧科技迷的微博视频

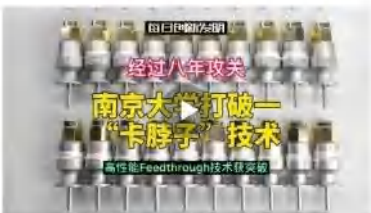

### 江苏省真空学会

江苏省真空学会常务理事单位牵头成功解决了Feedthrough“卡脖子”技术

江苏省真空学会 2021-08-04

近日，工信部国家工业信息安全发展研究中心给南京大学（江苏省真空学会常务理事单位）、中国科学院上海高等研究院、江苏安德信超导加速器科技有限公司（江苏省真空学会理事单位）、南京质子源工程技术研究院有限公司、安德信微波设备有限公司、长安大学、中恒国信企业管理集团有限公司七家单位颁发了“高性能Feedthrough关键技术开发与应用”科学技术成果登记证书。这意味着由南京大学现代工程与应用科学学院南京质子源孙安团队与中国科学院上海高等研究院、安德信科技等七家单位联合，经过八年科技攻关，终于打破了国外技术垄断，填补了国内空白，解决了高性能Feedthrough这一“卡脖子”技术。

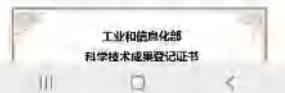

### 南京大学现代工学院团队牵头成功解决了Feedthrough“卡脖子”技术

天下为工 天下为工 1周前

近日，工信部国家工业信息安全发展研究中心给南京大学、中国科学院上海高等研究院、江苏安德信超导加速器科技有限公司、南京质子源工程技术研究院有限公司、安德信微波设备有限公司、长安大学、中恒国信企业管理集团有限公司七家单位颁发了“高性能Feedthrough关键技术开发与应用”科学技术成果登记证书。这意味着由南京大学现代工程与应用科学学院南京质子源孙安团队与中国科学院上海高等研究院、安德信科技等七家单位联合，经过八年科技攻关，终于打破了国外技术垄断，填补了国内空白，解决了高性能Feedthrough这一“卡脖子”技术。



# 做世界上最好的馈通！

Best Feedthroughs produced by ANDESUN!



## ANDESUN

<http://www.andesun.com>

安德信科技

ANDESUN Technology

地址：江苏省南京市栖霞区红枫科技园B4栋安德信科技

Add : Building B4, Hongfeng Science and Technology Park,  
Qixia District, Nanjing City, Jiangsu Province

联系 Contact

邮箱 Email : zhangyuelin@andesun.com

姓名 Name : Ms. Zhang, 张女士

手机 Phone : 18013431313